



FRAME BEARING SERVICE

CONTENT

Safety Information & Notices	3
Required Tools & Products	5
Bearing Tolerances & Fits	6
Bearing Press Parts	8
Bearing Press Basics	9
Linkage & Frame Inspection	11
Frame Disassembly	12
Bearing Inspection	13
Bearing Removal Linkages	14
Bearing Removal Frame	15
Bearing Clean and Prep	16
Pre-Assembly (Press Fit)	17
Frame Assembly	19
Geometry Flip Chip Assembly	22
Shock Mounting Metric Trunnion	24
Shock Mounting Metric Trunnion with Progressivity Flip Chip	25
Shock Mounting Metric Bushing with Travel Adjust Flip Chip	26
Shock Mounting Metric Bushing	27
Final Inspection	28



Safety Information & Notices

Warning

Due to the precision nature and high tolerances of Pivot Bicycles, if you do not have all the proper tools necessary and/or are not comfortable with performing frame disassembly, we highly advise and recommend that you visit your local Pivot dealer to perform the installation.

Damage to the frame or parts from improper removal/installation is NOT covered under warranty.

Failure to handle the installation correctly could result in a full frame failure. **PLEASE READ THE INSTRUCTIONS** and make sure that you own the proper equipment needed to properly install new bearings.

There are a lot of ways to remove and install bearings. We recommend the Enduro Bearing BRT-060 press for its high quality and precision parts that will ensure bearings are removed and installed correctly.

Consult the manufacturer's safe handling instructions for any assembly or cleaning products you use.

Know the safety and proper use of any bearing removal/installation tools you have before use. Damage or injury can be a result of improper use of tools.

Warranty Read the full warranty policy at <https://pivotcycles.com/warranty>



Safety Information & Notices

Safety Instructions

You must read and understand the safety documents included with your bike before proceeding with service. Improperly installed or serviced components are extremely dangerous and could result in severe and/or fatal injuries.

If you have any questions about the installation of these components, consult Pivot Cycles or your local Pivot dealer.

Notice

This guide will assist you with the removal, inspection, and installation of linkage assemblies. Do not attempt to remove/replace bearings in your frame or links without the proper tools and assembly products. As a general document, the components and process may differ from the pictures contained in this publication.

Always wear the following protective equipment when working on your bike.

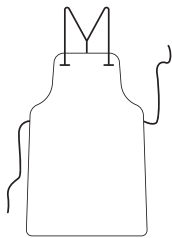

Apron



Nitrile Gloves



Safety Glasses

Required Tools & Products

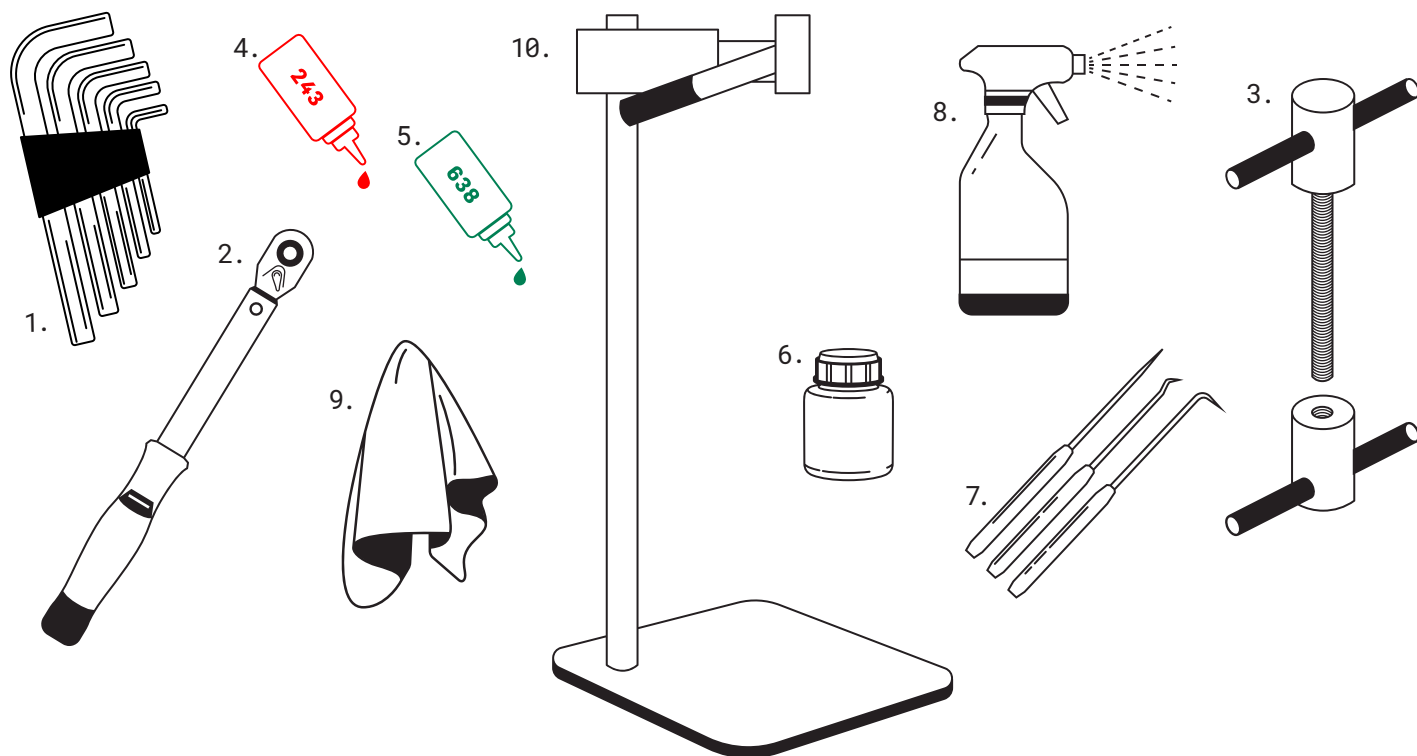

- | | |
|-----------------------------------|-----------------------------|
| 1. Metric Hex Wrenches | 6. Motorex Bike Grease 2000 |
| 2. Torque Wrench | 7. Dental Picks |
| 3. Enduro Bearing Press (BRT-060) | 8. Isopropyl alcohol |
| 4. Loctite 243 or equivalent | 9. Lint Free Rag |
| 5. Loctite 638 or equivalent | 10. Bicycle Repair Stand |

Service Procedure Time

We have listed an estimated service time for each of the steps of frame bearing service. These estimates are based on familiarity with the required tools and a general understanding of bicycle service. To complete a full inspection and replacement of all pivot bearings on a frame you should expect it to take 3-4 hours the first time you attempt this service.

Bearing Tolerances & Fits

Pivot's use of dw-link allows for short dual link designs. These compact linkages give us tighter frame alignment tolerances and stiffer overall frames along with our great pedaling and suspension feel.



The tighter control over our manufacturing tolerances means we can use more precise bearings. We use CN fit bearings for our frames instead of the more common C3 fit. The CN fit offers a perfect balance between reduced friction and solid fit. This also means that we see very long bearing life.



On all Pivot full suspension bikes we use two types of fits for our bearing pockets. Press fit and slip fit. It is such a small difference it is almost unmeasurable without precise instruments. The difference is $\sim 0.05\text{mm}$ of the inner diameter of the bearing pocket. Though that is a fraction of a millimeter it makes all the difference when assembling the bike.

With our precise manufacturing, strict QC, thoughtful assembly, and top quality Enduro Bearings we often see linkage bearings last for years without any replacement needed.



Bearing Tolerances & Fits

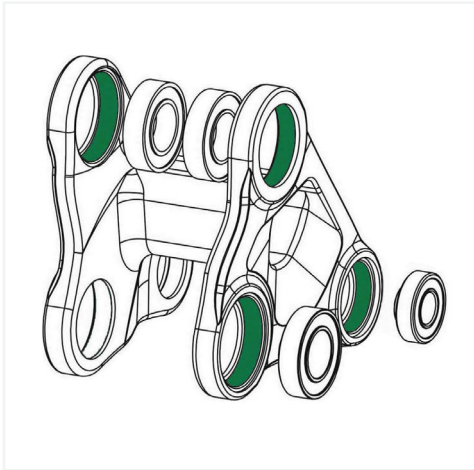

The process to assemble a frame has two steps for the bearing installation. Pre-assembly and frame assembly. During pre-assembly, the bearings in the press fit locations are installed into the links and frames. Once the press fit bearings are installed into the links they can be mounted to the drive side of the frame. The reason we always start with the drive side of the bike during assembly is it is the side that is the reference for all critical measurements for the bike.

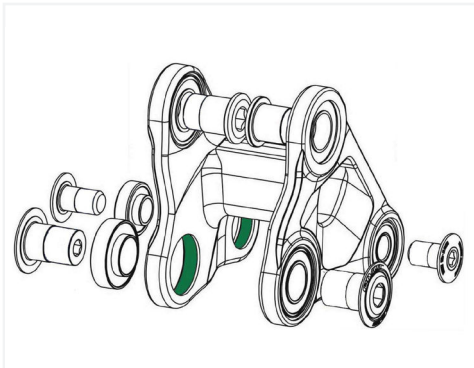

The bearings used in the slip fit locations will be installed during frame assembly, after the links have been mounted to the frame. The slip fit allows the bearings to be installed using the linkage bolts to seat them into the bearing pockets. This puts just the right preload and alignment on each bearing.

Where do you find the different fits?

Drive side bearings are press fit while some of the non drive side bearings are slip fit. The slip fit locations on the non drive side are found where a link is contacting the frame or to a trunnion mounted shock. Installing these bearings during frame assembly after the links have been mounted to the frame on the drive side allows for precise bearing and frame alignment.

Bearing Press Parts

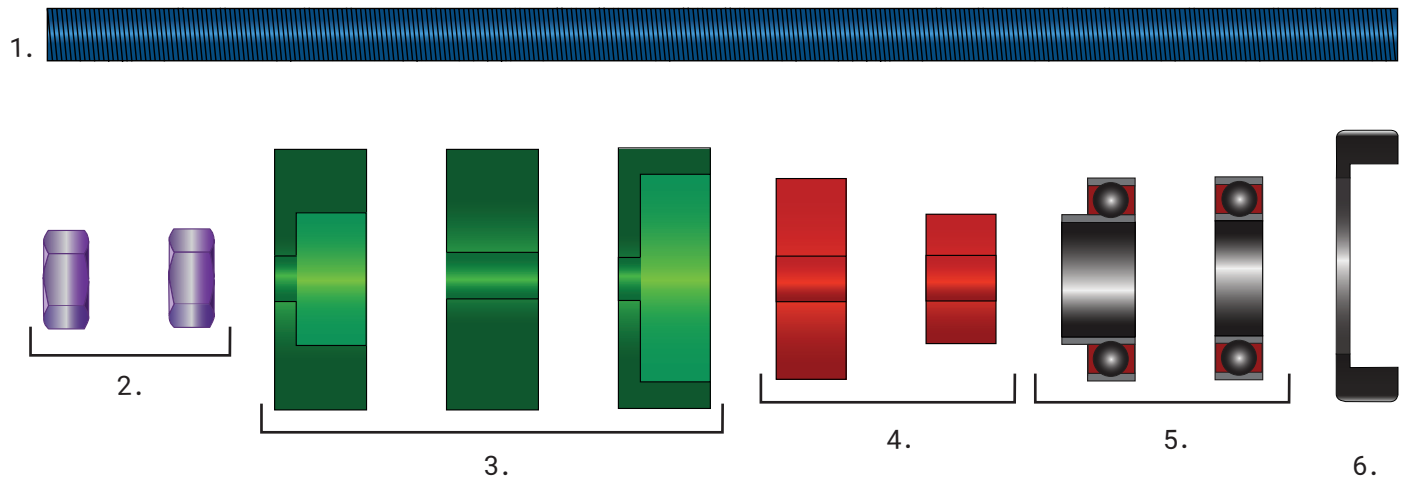

- | | |
|---------------------------|---------------|
| 1. Press Rod | 4. Press Body |
| 2. Press Nuts/Handles | 5. Bearings |
| 3. Press/Extractor Guides | 6. Link/Frame |

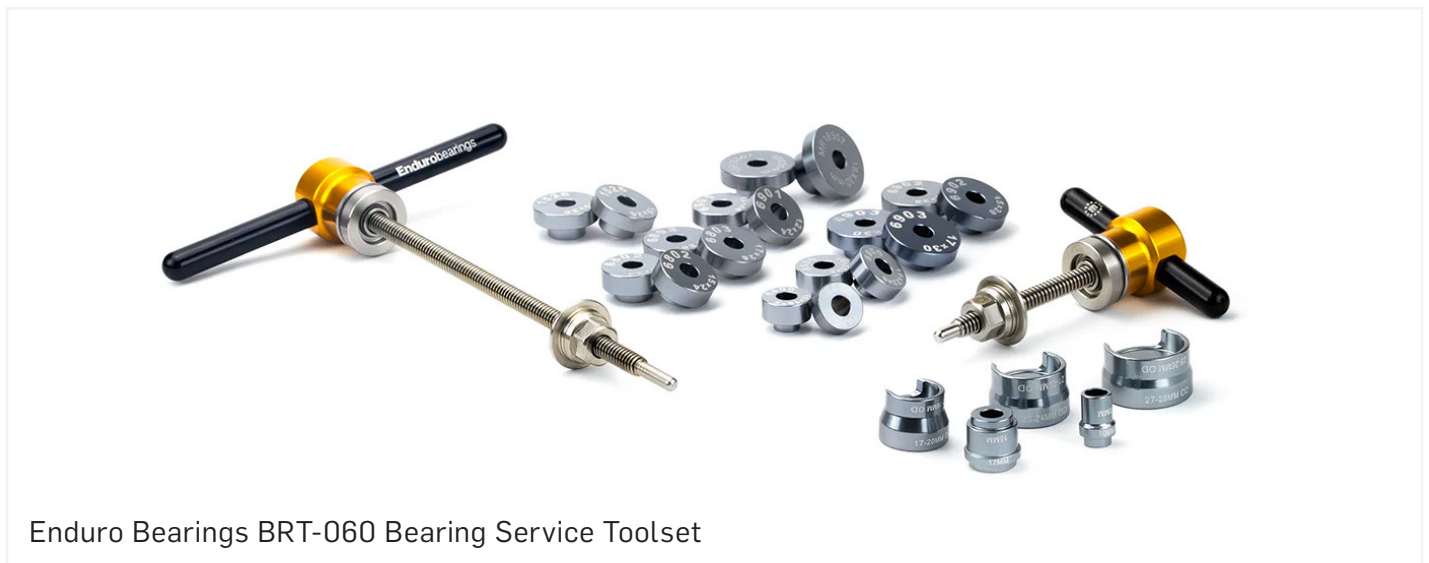

Enduro Bearings BRT-060 Bearing Service Toolset

Bearing Press Basics

Press fit bearing bores have a tight fit but it should not require excessive force to remove or install bearings.

If you feel resistance or see anything out of alignment, **STOP** and check your alignment and fittings. Misalignment can damage the bearing bore, link, or tool.

Never attempt to install or remove bearing by pressing across the whole link.

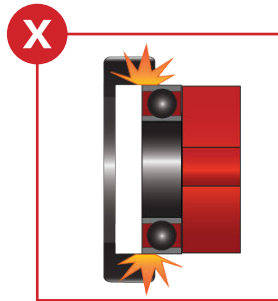
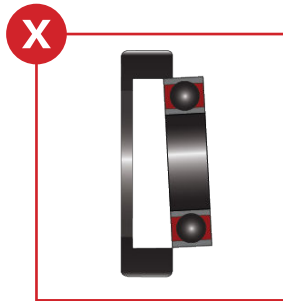

Always check that all the parts of your press are flush with the surfaces of the link you are removing/installing the bearing. Any misalignment can damage the bearing, link or your tools.

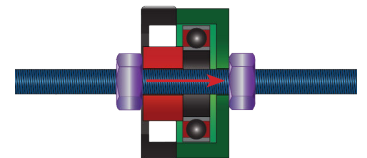
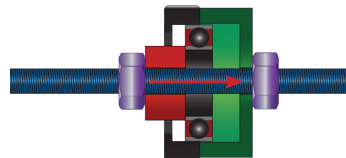
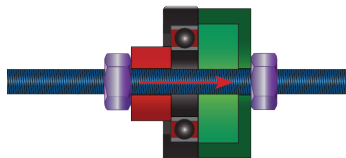

When removing a bearing the outer ring of the bearing is not accessible for pressing. Removal is the only time that a bearing should be pressed by the inner ring.

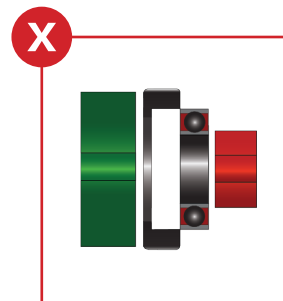
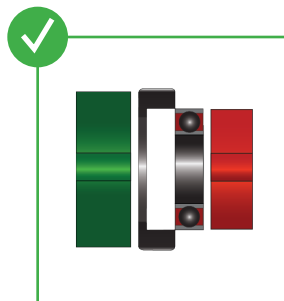

Bearing Press Basics

When installing extended race bearings begin by pressing the bearing in with a full surface guide behind the link or frame for best alignment and support for the bearing installation.

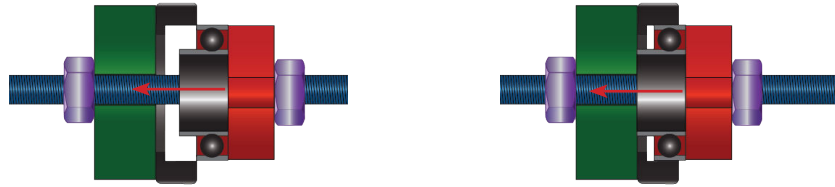

After pressing the bearing in to the guide, replace with a recessed guide and install the bearing completely.

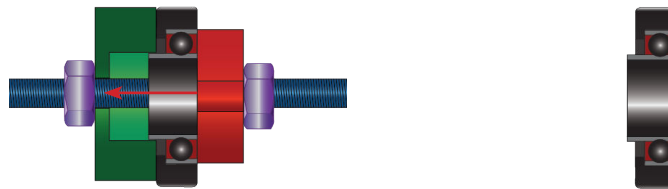

Linkage & Frame Inspection

Service Time: 20 Minutes

A simple check to see if your bearings are in good shape, is to run the frame through its full travel to feel the bearing movement.

To do this place your bike in a repair stand and remove the shock so you can move the rear triangle through its full travel.

Secure your bike in a repair stand.

Remove the rear wheel.

Place a rag on the downtube to protect the frame when you remove the shock.

Remove the upper shock mounting bolt(s).

**Some models require further frame disassembly to access the shock mounting hardware.*

Remove lower shock mounting bolt.

Carefully remove the shock from the frame.

Hold the rear triangle and rotate it up and through its full range of travel.

If the motion feels smooth the bearings are in good condition, and you can reinstall the shock. Proceed to the shock installation procedures.

If anything feels notchy, sticky or gritty then you will want to continue to frame disassembly.



Frame Disassembly

Service Time: 30 Minutes

Before you begin to disassemble the frame, it can be helpful to take pictures of the bike and orientation of links as you disassemble a bike for reference.

Pivot has small part schematics on the website for each model where you can reference part numbers and link orientation.

Every lower link is stamped with an arrow or mark on the non-drive side pointing to the front triangle. This makes it easy to always get the lower link mounted in the correct orientation.

- Secure your bike in repair stand.
- Remove rear wheel.
- Place a rag on downtube of the frame to protect it when removing the shock.
- Remove the cranks from the frame.
- Loosen all linkage bolts half a turn before disassembly.
- Remove upper and lower shock mounting bolts.
- Loosen and remove seat stay linkage bolts or flip chip bolts, chips and spacers.
- Loosen and remove upper linkage mounting bolts and remove upper link from frame.
- Carefully peel the lower link protect off the Front and Rear triangles leaving it attached to the lower link. You can reuse it this way or remove and apply a new one during assembly.



Frame Disassembly

Loosen and remove the rear lower link bolts from the rear triangle.

You can use a strap to secure the rear triangle from hanging on the housing. If you need to remove the rear triangle completely for use with your bearing tool then you will need to disconnect the rear brake line and shift housing and remove it from the front triangle.

Loosen and remove the front two lower link bolts and remove the lower link from the frame.

Bearing Inspection

Service Time: 10 Minutes

With links fully removed you can check the feel of each individual bearing.

Spin each bearing making sure they are not feeling notchy, sticky or gritty.

Hold the inner race and outer race and check for any play between them.

Suspension Pivot bearings are designed to only move a few degrees not to spin like a wheel bearing. They are designed to handle loads from all direction and be well sealed so these will not continue spinning on their own.

Bearings that still feel good can be left for reassembly.

Any bearing that is seized, has play or is notchy should be replaced.

If all bearing are good then you can reassemble the frame.



Bearing Removal Linkages

Service Time: 30 Minutes

Prepare your press with the proper fittings for the bearing size you are removing.

Check which direction the bearing needs to be removed from the link.

Confirm everything is aligned properly and begin to press the bearing out.

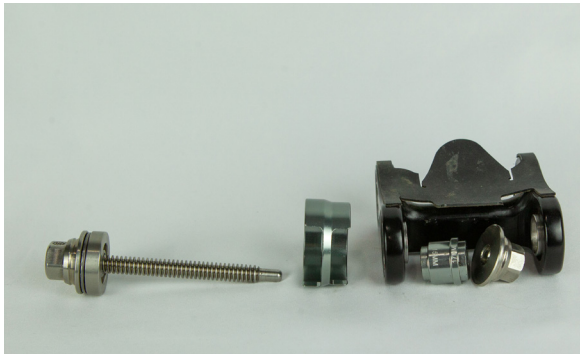

Stop and check frequently to make sure alignment is good.

If you feel any binding or increased resistance remove the press and inspect the link, bearing, and press.

Continue this process until all bearings being replaced are removed from the links.

Bearing Removal Frame

Service Time: 15 Minutes

Use extreme caution when removing bearings from the frame where the paint could be damaged or chipped. Damage to the paint or finish is *NOT* covered under warranty. We highly recommend you have your local Pivot dealer remove and install these bearings for you.

Depending on what tools you are using you may need to disconnect your brake and or shift housing to separate the rear triangle from the front triangle to properly press the bearings out. A blind hole puller and slide hammer is often the best option for removing bearings pressed into the frame.

Select the proper fittings for the bearing size you are removing.

Check which direction the bearing needs to be removed from the frame.

Insert the blind hole puller into the bearing and tighten it down.



Protect and support the frame securely so you will not damage the frame while using the force of the slide hammer.



Attached the slide hammer to the fitting and begin hammering to remove.

Continue this process until all bearings being replaced are removed from the frame.

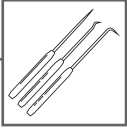
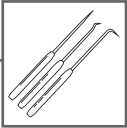

Bearing Clean and Prep

Service Time: 20 Minutes

-  Clean the outer race of each bearing with isopropyl alcohol. Even new bearings can have some residue on them from manufacturing.
-  Use a pick to clean the frame, bolt, and shock threads of any cured thread locker or dirt.
-  Use a pick to clean the bearing pocket of an cured retaining compound.
-  Clean everything with isopropyl alcohol and a lint free rag and let dry.



Pre-Assembly (Press Fit)

Service Time: 30 Minutes

Pre-Assembly is what we call the press fit bearing installation process to prepare everything for assembly.

Refer to the assembly documents for your frame for the location of press fit bearings. In general, these locations are going to be any bearings pressed into the frame, drive side linkage bearing pockets and geometry flip chip bearings.

For bearings with extended inner races you will need to make sure what you are using has a recess for the bearing to be pressed fully into the pocket.

Step 1.

Apply a small amount of Loctite 638 to a bearing pocket and use a round wooden toothpick to spread around the bearing pocket until there is a thin layer all the way around the pocket. Continue this for all link and frame bearing pockets.



Step 2.

Prepare your press with the proper fittings for the bearing size you are installing. Check which direction the bearing needs to be pressed into the link.



Pre-Assembly (Press Fit)

Step 4.

Confirm everything is aligned properly and begin to press the bearing in.

Tip: When installing extended race bearings begin by pressing the bearing in with a full surface guide behind the link or frame for best alignment. After pressing the bearing in to the guide, replace with a recessed guide and install the bearing completely.



Step 5.

Stop and check frequently to make sure alignment is good. If you feel any binding or increased resistance STOP and remove the press and inspect the link, bearing, and press.



Step 6.

If pressing in an extended race bearing use a recessed guide to complete the installation.

Confirm the bearing is pressed completely and evenly into the pocket.

Continue this process until all press fit bearings are installed.



Frame Assembly

Service Time: 45 Minutes

With all press fit bearings installed you can begin mounting the links to the frame.

Step 1.

Apply Loctite 243 or an equivalent to the frame, link, or chip threads, NOT THE BOLT THREADS. Use a round wooden toothpick to evenly spread around the threads.

Tip: Applying the Loctite to the bolt threads or using too much can cure between the bolt head and bearing. This glues them together and makes it very difficult to separate the bolt from the bearing.



Step 2.

Begin with the drive side of the lower link. Confirm you have the link oriented correctly with the arrow on the link on the non-drive side pointing forward.

Tip. If installing a new Lower Link protector remove film from the adhesive for the link shape leaving the film on the front and rear triangle contacting locations. Press the protector on the lower link firmly for good adhesion.



Step 3.

Align the drive side of the lower link with the front triangle.

Insert the bolt through the link and thread it into the frame. Torque the bolt to the value etched on the bolt.

Rotate the link to confirm smooth motion.



Frame Assembly

Step 4.

On the non-drive side, insert a lower link bolt into a lower link bearing.

If you haven't already, apply loctite 638 or an equivalent to the bearing pocket and spread evenly.

Align the bearing and bolt and begin threading the bolt into the frame. The bolt will work as the press for this bearing.

Torque the bolt to the value etched on the bolt.

Rotate the link and confirm smooth motion.



Step 5.

Check orientation of upper link and align the drive side. Thread a bolt through the link into the frame.

Torque the bolt to the value etched on the bolt.

Rotate the link and confirm smooth motion.



Step 6.

Insert an upper link bolt into an upper link bearing.

If you haven't already, apply Loctite 638 or an equivalent to the bearing pocket and spread evenly. Align the bearing and bolt with the non-drive side location and begin threading the bolt into the frame.

Torque the bolt to the value etched on the bolt.

Rotate the link and confirm smooth motion.



Frame Assembly

Step 7.

Align the bottom of the rear triangle's drive side with the drive side lower link. Insert the bolt through the link and thread it into the frame.

Torque the bolt to the value etched on the bolt.



Step 8.

On the non-drive side, insert a lower link bolt into a lower link bearing.

If you haven't already, apply loctite 638 or an equivalent to the bearing pocket and spread evenly. Align the bearing and bolt and begin threading the bolt into the frame.

Torque the bolt to the value etched on the bolt.

Rotate the rear triangle and confirm smooth motion.



If your frame has a geometry flip chip proceed to the next page.

Step 9.

Rotate the rear triangle up and align the drive side RT bearing with the upper link. Insert a bolt into the upper link and torque the bolt to the value etched on the bolt. Rotate the frame to confirm smooth motion.

Step 10.

On the non-drive side, insert a bolt through the bearing into the upper link and torque the bolt to the value etched on the bolt. Rotate the frame to confirm smooth motion.

Proceed to shock installation for your model's configuration.



Geometry Flip Chip Assembly

Service Time: 15 Minutes

1.



Apply Motorex Bike Grease 2000 or equivalent to both sides of each washer.

Grease the frame contacting surfaces of the flip chip or the flip chip pocket on the frame. Take care not to get any grease on the threads.

2.



Apply Loctite 243 or equivalent to the flip chip threads and spread around with a round wooden toothpick.

You can either install the flip chips into the frame pockets or align the link in the rear triangle and insert the bolts. Either method works well, however, we will describe inserting the bolts option.

3.

Position the washers on the bearings of the upper link to fit between the bearing and the rear triangle. They should stick in place with the grease.

4.

Position the upper link in the rear triangle taking care not to drop the washers as it goes into place.

5.

Insert one of the flip chip bolts through the link and frame and align with the flip chip. This can be easier if the frame and link are rotated forward into its travel direction.

6.

Insert the flip chips into the frame with the hole in the desired flip chip positions.



Geometry Flip Chip Assembly

7.

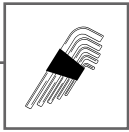

Use a 6mm wrench to snug the bolt into the flip chip.

8.

Repeat this process on the other side.

9.

Torque both flip chip bolts to the value etched on the bolt. (You will need to set your wrench to counterclockwise.)

10.





Rotate the rear triangle through its travel to confirm smooth motion.

Proceed to shock installation for your model's configuration.

Shock Mounting | Metric Trunnion

Service Time: 15 Minutes

- 

1. Place a rag on the downtube to protect the frame when installing the shock.
- 

2. Apply a small amount of Loctite 243, or equivalent, to the lower shock tab frame threads. Spread evenly with a wooden toothpick. *Loctite can damage paints and finishes so use caution.*

Apply a small amount of Loctite 243, or equivalent, to the shock trunnion mount threads. Spread evenly with a wooden toothpick.
- 

3. Apply Motorex Bike Grease, or equivalent, to the head and shaft of the lower shock bolt. *Avoid getting grease on the threads.*

Apply grease to the faces of the shock eyelet spacers.
4. Position the shock in the shock tabs to line up the lower shock bolt. Install the lower shock bolt.

Torque to the value etched on the bolt.
5. Align the drive side of the upper link with the shock and install one of the trunnion mounting bolts.

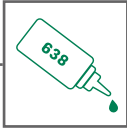
Torque to value etched on the bolt.
- 

6. On the non-drive side, insert a trunnion mounting bolt into a trunnion bearing.

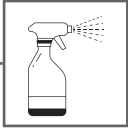
If you haven't already, apply loctite 638 or an equivalent to the bearing pocket and spread evenly.
7. Align the bearing and bolt and begin threading the bolt into the frame. Torque the bolt to value etched on the bolt.
- 

8. Clean any excess grease, retaining compound, or thread locker from any frame parts with isopropyl alcohol and a rag.

Shock Mounting | Metric Trunnion with Progressivity Flip Chip

Service Time: 15 Minutes

- 

1. Place a rag on the downtube to protect the frame when installing the shock.
- 

2. Apply a small amount of Loctite 243, or equivalent, to the lower shock mount flip chip threads. Spread evenly with a wooden toothpick. *Loctite can damage paints and finishes so use caution.*

Apply a small amount of Loctite 243, or equivalent, to the trunnion mount threads. Spread evenly with a wooden toothpick.
- 

3. Apply Motorex Bike Grease, or equivalent, to the head and shaft of the lower shock bolt. *Avoid getting grease on the threads.*

Apply grease to the faces of the shock eyelet spacers.

Apply grease to the frame contacting surface of the flip chips.
4. Install the flip chips into the frame in your desired position. Bolt forward for more linear, rearward for more progressive.
5. Position the shock in the shock tabs to line up the lower shock bolt with the flip chips. - Install the lower shock bolt, holding the non-drive side flip chip as you thread the bolt in. Torque to value etched on the bolt.
- 

6. Align the drive side of the upper link with the shock and install one of the trunnion mounting bolts. Torque to value etched on the bolt.

7. On the non-drive side, insert a trunnion mounting bolt into a trunnion bearing. - If you haven't already, apply loctite 638 or an equivalent to the bearing pocket and spread evenly.
8. Align the bearing and bolt and begin threading the bolt into the frame. Torque the bolt to value etched on the bolt.
- 

9. Clean any excess grease, retaining compound, or thread locker from any frame parts with isopropyl alcohol and a rag.

Shock Mounting | Metric Bushing with Travel Adjust Flip Chip

Service Time: 20 Minutes

- 

1. Place a rag on the downtube to protect the frame when installing the shock.
- 

2. Apply a small amount of Loctite 243, or equivalent, to the lower shock tab frame threads and upper shock mount flip chip threads. Spread evening with a wooden toothpick. *Loctite can damage paints and finishes so use caution.*
- 

3. Apply Motorex Bike Grease, or equivalent, to the head and shaft of the upper and lower shock bolts. Avoid getting grease on the threads.

Apply grease to the faces of the shock eyelet spacers.

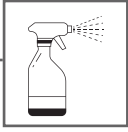
Apply grease to the frame contacting surface of the flip chips and the flip chip spacers.
4. Install the flip chips into the link in your desired position. *Bolt forward for less travel, rearward for more travel.*
5. Position the shock in the shock tabs to line up the lower shock bolt. Install the lower shock bolt. Torque to value etched on the bolt.
6. Align the drive side of the upper link, shock, and flip chips.
7. Insert the upper shock bolt, holding the non-drive side flip chip as you thread the bolt in. Torque to value etched on the bolt.
- 

8. Clean any excess grease, retaining compound, or thread locker from any frame parts with isopropyl alcohol and a rag.

Shock Mounting | Metric Bushing

Service Time: 10 Minutes

- 

1. Place a rag on the downtube to protect the frame when installing the shock.
- 

2. Apply a small amount of Loctite 243, or equivalent, to the upper and lower frame shock tab threads. Spread evening with a wooden toothpick. Loctite can damage paints and finishes so use caution.
- 

3. Apply Motorex Bike Grease, or equivalent, to the head and shaft of the upper and lower shock bolts. Avoid getting grease on the threads.
Apply grease to the faces of the shock eyelet spacers.
4. Position the shock in the lower shock tabs to line up the lower shock bolt.
5. Install the lower shock bolt. - Torque to the value etched on the bolt.
6. Align the shock with the upper shock tabs.
7. Install the upper shock bolt. Torque to the value etched on the bolt.
- 

8. Clean any excess grease, retaining compound, or thread locker from any frame parts with isopropyl alcohol and a rag.

Final Inspection

Service Time: 10 Minutes

- Confirm all bolts are torqued to proper spec.
- Pull any slack out of any housing from the rear of the bike forward.
- Check any cable port covers or guides you may have loosened or removed.
- Check for any excess grease, retaining compound, or threadlocker and clean from any frame parts with isopropyl alcohol and a rag.
- Install the rear wheel and torque the axle down to spec.
- Give your bike a pre-ride check confirming that all components are working properly and everything is installed correctly.

If you applied a new lower link protector, remove the remaining film and apply the parts to the front and rear triangle.

Tip: if pressed low and tight the adhesive can make noise as the bike goes through its travel until it wears in.

