

SHUTTLE AMP'D

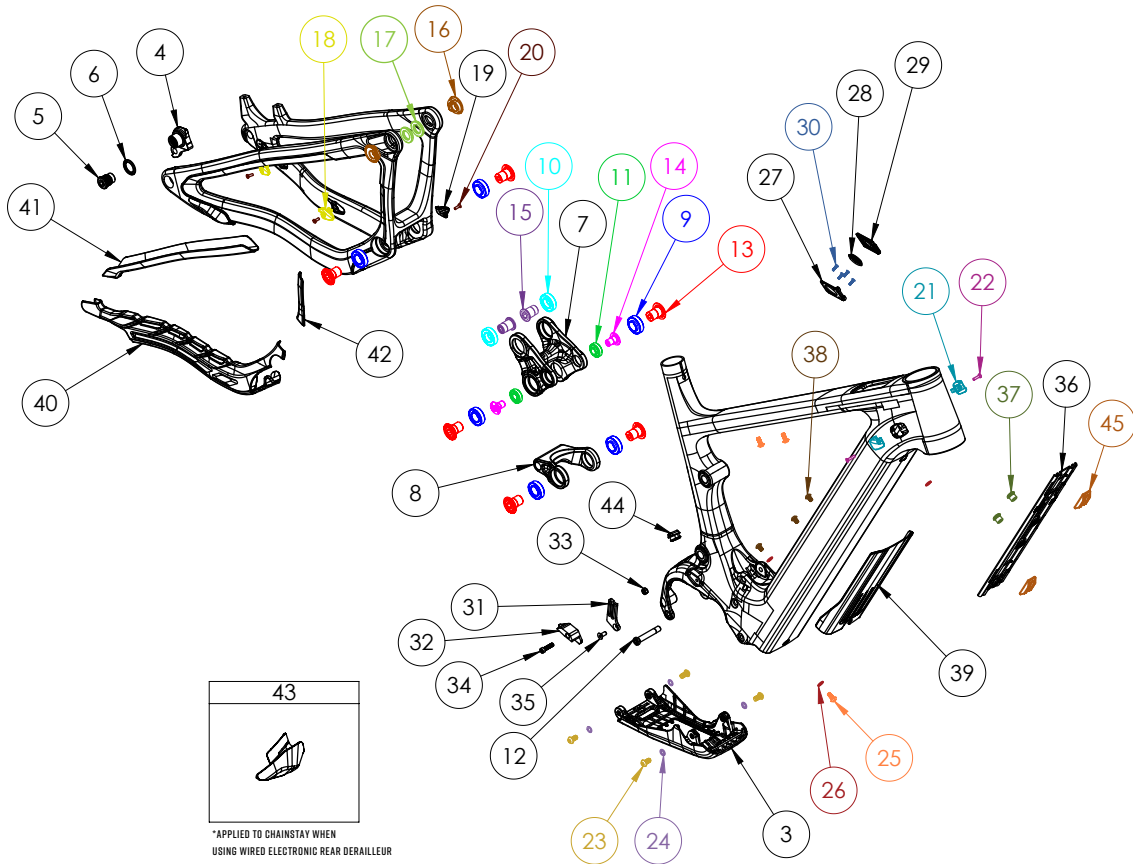

HARDWARE NUMBER	PART NUMBER	DESCRIPTION	TORQUE	*
3	FP-CVR-SAMPI-SKD-VI-RI	SHUTTLE AMP'D SKID PLATE		
4	FP-UDH-TA-12MM-BLK-V2-RI	UNIVERSAL REAR DERAILLEUR HANGER		
5	(INCLUDED WITH #4)	UNIVERSAL REAR DERAILLEUR HANGER BOLT	25 NM (18 LB-FT)	
6	(INCLUDED WITH #4)	UNIVERSAL REAR DERAILLEUR HANGER WASHER		
7	FP-LNK-UL-66MM-VI-RI	66MM UPPER LINK		
8	FP-LNK-LL-50MM-V4-RI	50MM OUT-TO-IN LOWER LINK		
9	FP-BRG-6902-LLUMAXECN	28MM 6902 EXTENDED MAX-E BEARING - BLACK OXIDE		R
10	FP-BRG-6902-LLUMAX	28MM 6902 STANDARD MAX BEARING - BLACK OXIDE		R
11	FP-BRG-6900-LLUMAXE	22MM 6900 EXT'D MAX-E BEARING - BLACK OXIDE		R
12	FP-BLT-M8*45.7-BLK-V2	M8 FRONT SHOCK BOLT FOR 30.1MM SHOCK SPACING	13 NM (10 LB-FT)	G / L
13	FP-BLT-M14*20-BLK-V2-R2	M14X20 LINK BOLT	35 NM (27 LB-FT)	L
14	FP-BLT-M10*16.5-BLK-VI	M10 TRUNNION MOUNT BOLT	13 NM (10 LB-FT)	L
15	FP-BLT-M14*20-BLK-V3-R2	M14X20 FLIP CHIP BOLT	35 NM (27 LB-FT)	L
16	FP-NUT-FLIPCHIP-4.6MM-VI	4.6MM FLIP CHIP		G
17	FP-WSH-SPD-151*250*3W	M14X3MM FLIP CHIP SPACER		G
18	FP-CLM-MECH-FRM-VI	INTERNAL ROUTING CABLE CLAMP		
19	FP-CLM-DUAL-FRM-VI	INTERNAL ROUTING DUAL CLAMP		
20	FP-SCW-FLT-M3*10-BLK	M3X10 CABLE PORT SCREW		
21	FP-CLM-PORT-SINGLE-VI-RI	DUAL PORT - SINGLE CLAMP		
22	FP-SCW-FLT-M3*15-BLK	DUAL PORT CLAMP SCREW BLACK		
23	FP-SCW-BTN-M6*12-VI-RI-BLK	M6X12 SKID PLATE MOUNTING SCREWS	6 NM (4.4 LB-FT)	L
24	FP-WSH-M6-BLK-VI-RI	M6 WASHER BLACK		
25	FP-BLT-BTN-M5*12-VI-RI-BLK	M5X12 BUTTON HEAD SCREW	5 NM (4 LB-FT)	L
26	FP-WSH-M5*10*1-VI-RI	M5 WASHER		
27	FP-MNT-BATT-CHG-V2-RI	AVINOX CHARGER MOUNTING PLATE		
28	FP-AVX-GKT-BATT-CHG-VI-RI	AVINOX CHARGER GASKET		
29	FP-AVX-CVR-BATT-CHG-VI-RI	AVINOX CHARGER TOP CAP		
30	FP-BLT-FLT-M2.5*10-VI-RI-BLK	M2.5X10 FLAT HEAD BOLT BLACK	1 NM (8.8 IN-LB)	
31	FP-MNT-CG-V5	CHAIN GUIDE MOUNTING PLATE		
32	GH 1042B UPPER-20	UPPER CHAIN GUIDE		
33	(INCLUDED WITH #32)	M5 LOCKNUT		
34	(INCLUDED WITH #32)	M5X20 SOCKETHEAD SCREW		
35	FP-SCW-FLT-M5*12-BLK	M5X12 FLAT HEAD CG MOUNTING SCREW	5 NM (4 LB-FT)	L
36	FP-GDE-WIRE-PLATE-V2-RI	INTERNAL ROUTING PLATE		
37	FP-BLT-M10*8.5-VI-RI	INTERNAL ROUTING PLATE BOLT	2 NM (1.5 LB-FT)	G
38	FP-SCW-BTN-M5*8	M5X8 BUTTON HEAD SCREW		
39	FP-PRO-SAMPI-DT-VI-RI	SAMPI DOWNTUBE PROTECTOR		
40	FP-PRO-SAMPI-CS-VI-RI	SAMPI CHAINSTAY PROTECTOR		
41	FP-PRO-SLAMI-SS-VI-RI	SLAMVI SEATSTAY PROTECTOR		
42	FP-PRO-SLAMI-UR-VI-RI	SLAMVI UPRIGHT PROTECTOR		
43	FP-GDE-WIRE-VI-RI	SAMPI RD WIRE GUIDE		
44	FP-PLG-SPD-EBIKE-VI-RI	SPEED SENSOR PLUG		
45	FP-PAD-INT-CABLE-ROUTE-VI	INTERNAL ROUTING PLATE PAD		

NOT PICTURED	PART NUMBER	DESCRIPTION	TORQUE	*
-	157MM THROUGH AXLE V5	157MM UDH REAR AXLE	15 NM (11 LB-FT)	G
-	-	12MM AXLE WASHER (INCLUDED W/ AXLE)		G

BIKE CARE				
*	PRODUCT TYPE	RECOMMENDED PRODUCT		
G	GREASE	MOTOREX BIKE GREASE 2000		
L	THREAD LOCKER**	LOCTITE THREAD LOCKER #243 (OR EQUIVALENT)		
G/L	GREASE (BOLT SHAFT) / THREAD LOCKER (BOLT THREADS)	SEE ABOVE		
A	ANTI-SEIZE	MOTOREX COPPER PASTE		
Y	LIGHT DUTY THREAD LOCKER	LOCTITE THREAD LOCKER #222 (OR EQUIVALENT)		
R	RETAINING COMPOUND	LOCTITE RETAINING COMPOUND #638 (OR EQUIVALENT)		

**THREADLOCKER SHOULD ALWAYS BE APPLIED TO THE CORRESPONDING FEMALE THREADS FOR THE BOLT SPECIFIED



SHUTTLE AMP'D AVINOX SYSTEM PARTS

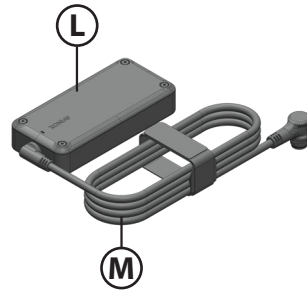
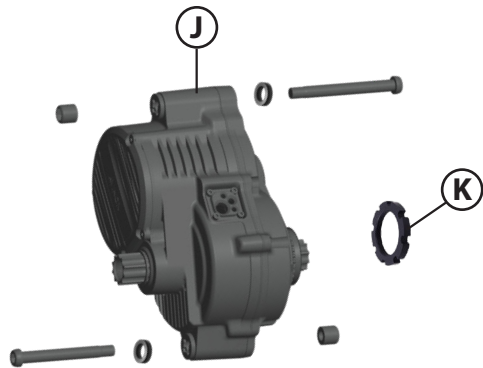
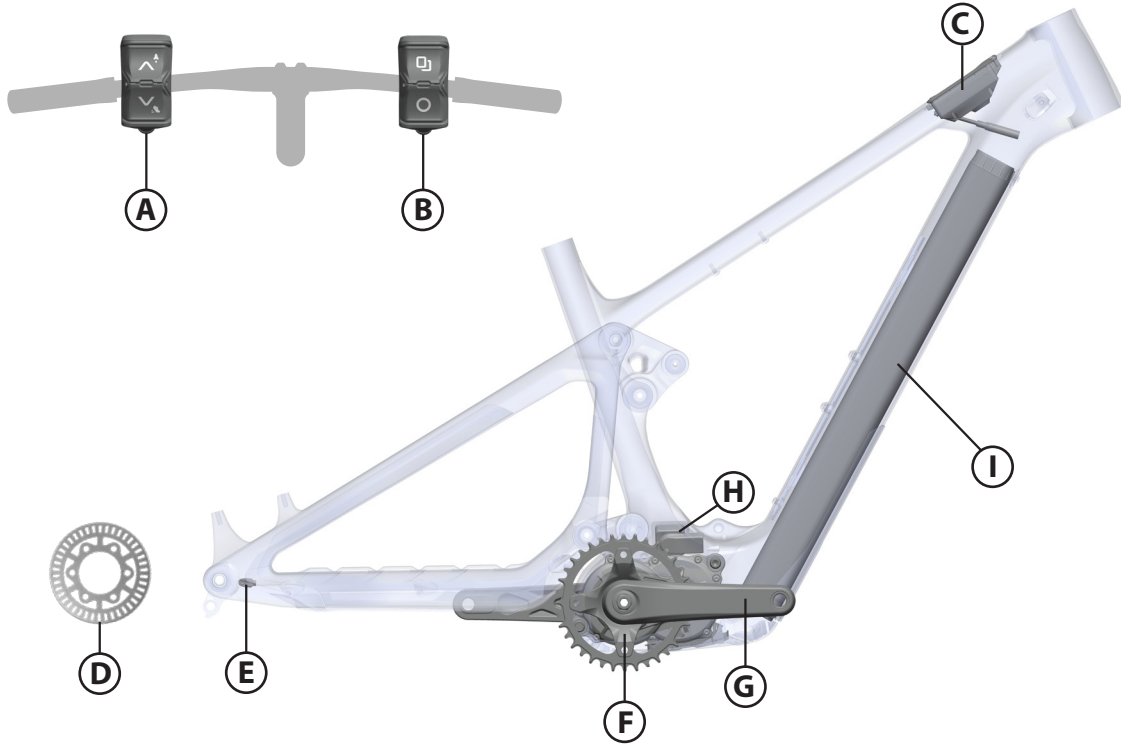

*DRIVE UNIT MOUNT WASHER KIT INCLUDES TWO SERRATED WASHERS. ALIGN THE LARGE SERRATIONS OF THE WASHERS ACCORDING WHITE DOT TO WHITE DOT, THEN PLACE THEM TOGETHER AND INSTALL THEM ONTO THE DRIVE UNIT MOUNT BOLT.

PARTS & COMPONENTS				
LETTER	PART DESCRIPTION	PART NAME	TORQUE	*
A	LEFT WIRELESS CONTROLLER	CP.EB.00000079.01		
B	RIGHT WIRELESS CONTROLLER	CP.EB.00000078.01		
C	CONTROL DISPLAY (NA REGIONS) CONTROL DISPLAY (GLOBAL REGIONS) DISPLAY CABLE (710MM)	CP.EB.00000104.01 CP.EB.00000105.01 CP.EB.00000096.01		
D	SPEED SENSOR RING	CP.EB.00000102.01		
E	SPEED SENSOR AND MOUNTING HARDWARE (650MM)	CP.EB.00000219.01		
F	SPIDER, BASH RING, AND CHAINRING	EP08A-DJAM1-DG-C55/ B650/ 00.6218.034.003		
G	CRANK ARMS (TEAM BUILD) CRANK ARMS (PRO & RIDE BUILDS)	EC-2ISIS-155AM EC-2ISIS-155CM		
H	CHARGING SOCKET	CP.EB.00000203.01		
I	800WH BATTERY AND MOUNTING HARDWARE	CP.EB.00000127.02	5 NM (4 LB-FT)	L
J	AVINOX M2S DRIVE UNIT AND MOUNTING HARDWARE	CP.EB.00000210.01	25 NM (18 LB-FT)	L
K	CHAINRING SPIDER LOCKRING	CP.EB.00000089.01	35 NM (27 LB-FT)	G
L	AVINOX I2A FAST CHARGER-NO POWER CABLE (TEAM AND PRO BUILDS) AVINOX 4A STANDARD CHARGER-NO POWER CABLE (RIDE BUILDS)	CP.EB.00000125.01 CP.EB.00000116.01		
M	I2A CHARGER POWER CABLE (UK) I2A CHARGER POWER CABLE (AU) I2A CHARGER POWER CABLE (CN) I2A CHARGER POWER CABLE (US) I2A CHARGER POWER CABLE (EU)	CP.EB.00000120.01 CP.EB.00000121.01 CP.EB.00000122.01 CP.EB.00000123.01 CP.EB.00000124.01		
M	4A CHARGER POWER CABLE (UK) 4A CHARGER POWER CABLE (AU) 4A CHARGER POWER CABLE (CN) 4A CHARGER POWER CABLE (US) 4A CHARGER POWER CABLE (EU)	CP.EB.00000111.01 CP.EB.00000112.01 CP.EB.00000113.01 CP.EB.00000114.01 CP.EB.00000115.01		

NOT PICTURED	PART DESCRIPTION	PART NAME	TORQUE	*
-	DRIVE SYSTEM SCREW KIT	CP.EB.00000080.02		
-	AVINOX LOCKRING TOOL	CP.EB.00000088.01		
-	AVINOX MOTOR MOUNTING POINT ADJUSTMENT TOOL	CP.EB.00000211.01		
-	DRIVE UNIT SCREW KIT (DRIVE UNIT FR MNT BOLTS, RR MNT BOLTS, 4 SPCRS, 2 MNT NUTS)	CP.EB.00000254.01		