



PIVOT
CYCLES

SHUTTLE AMP'D



PIVOT Shuttle AMP'd *Original Operational Instructions*

This manual is intended to provide you with the information needed to get you on the trail, walk you through the steps necessary to set up components, and become familiar with the AVINOX E-bike System. This document contains some helpful diagrams and reference material to make sure you have everything necessary to maintain your Shuttle AMP'd and enjoy it to the fullest.



TABLE OF CONTENTS		PAGE
1. Quick Start Guide		1
- Basic Suspension Setup		1
- Recommended Tire Pressure		1
- Adjusting Saddle Height		1
- Charging the Battery		1
- Avinox System Controls		2
- Control Display & Wireless Controller Function		2
- Smartphone Connection and App Pairing		2
2. Bike Set-up		3
- Setting Shock Sag		3
- Setting Damping on FOX Float X Rear Shocks		4
- Setting Damping on RockShox Super Deluxe Shocks		5
- Setting Fork Sag		6
- Setting Damping on FOX Forks		6
- Setting Damping on RockShox Forks		7
3. System Operation		8
- Riding Mode Customization		8
- Walk Mode		8
- Boost Mode		8
- SmoothShift		8
- System Updates		8
- Troubleshooting		8
5. Advanced System Functions		9
- Adding Accessories		9
- Pairing a Wireless Controller		9
- Installing a nano-SIM Card		9
- Bike Protection		9
6. Schematics		10
- Small Parts Schematic		10
- Small Parts Table		11
- Avinox System Schematic		12
- Wiring Diagrams		13
7. Additional Information		14
- Safety Information		14
- Sources		16
- My Settings & Notes		16



QUICK START SUSPENSION SETTINGS		
Shock Air Pressure (By Body Weight)	Body Weight in [lbs] to [psi]	Float X: Body Weight [lbs] + 40 [psi] Super Deluxe Ultimate: Body Weight [lbs] + 50 [psi]
	Body Weight in [kg] to [psi]	Float X: 2.2 × Body Weight [kg] + 40 [psi] Super Deluxe Ultimate: 2.2 x Body Weight[kg] + 50 [psi]
Check Sag Always! see page 3	Body Weight in [kg] to [bar]	Float X: 0.15 × Body Weight [kg] + 2.8 [bar] Super Deluxe Ultimate: 0.15 x Body Weight[kg] + 3.4 [bar]
	Body Weight in [lbs] to [bar]	Float X: 0.07 × Body Weight [lbs] + 2.8 [bar] Super Deluxe Ultimate: 0.07 x Body Weight[lbs] + 3.4 [bar]
Shock Compression Damping		Float X: 8 clicks in from OPEN Super Deluxe: LSC: Middle HSC: -2 clicks
Shock Rebound Damping		Float X: 6 clicks in from OPEN Super Deluxe: 7 clicks in from OPEN
Fork Air Pressure		FOX 38: 80 [psi] / 5.52 [bar] RockShox Zeb: 70 [psi] / 4.82 [bar]
Fork Compression Damping		FOX 38: HSC: 3 clicks in from OPEN LSC: 5 clicks in from OPEN Zeb Ultimate: HSC: Middle LSC: Middle
Fork Rebound Damping		FOX 38: HSR: 3 clicks in from OPEN LSR: 9 clicks in from OPEN Zeb Ultimate: 8 clicks from OPEN

*These quick start settings can get the average rider a starting point. Continue to page 3 for more specific suspension setup.

Recommended Tire Pressure

Front: 23 psi (1.58 bar) Rear: 28 psi (1.93 bar)

- Tire pressure is an important factor for having your e-bike ride properly.
- If the tire pressure is too high, the tire will not conform to the ground, reducing traction. If the tire pressure is too low, the tire could pinch flat. It is important to have an accurate pressure gauge when setting tire pressure.

Adjusting Saddle Height

1. Use a 2 mm hex wrench, loosen the drive side cable port cap securing the dropper post housing. (fig. 1)
2. Using a 4 mm hex wrench, loosen the seatpost clamp bolt (fig. 2) and raise/lower the saddle to the preferred height.
3. Using a 4 mm hex wrench, tighten the seatpost clamp bolt to 5 Nm.
4. Tighten the cable port cap screw with a 2 mm hex wrench to secure the dropper post housing.

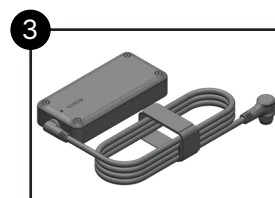
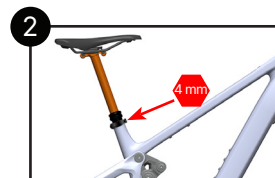
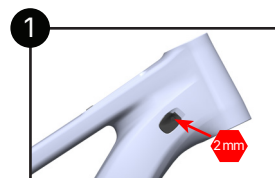

Charging the Battery

NOTE: The battery does not come fully charged and must be charged completely before the first use.

1. Prepare your Avinox charger. (fig. 3)
2. Locate the charging port on the non-drive side of the frame. (fig. 4)
3. Open the magnetic cover to access the charging terminal. (fig. 4)
4. Insert the charging cable into the charging terminal, ensuring the cable and terminal are properly aligned. (fig. 5)
5. When charging, the LED indicator on the charger will illuminate red and the Control Display screen will show the current battery level. The LED indicator will illuminate green when charging is complete. A charging error occurred when the LED indicator is yellow.
6. When done charging, remove the cable from the terminal and close the sealing cover.

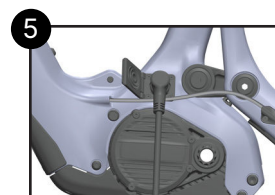
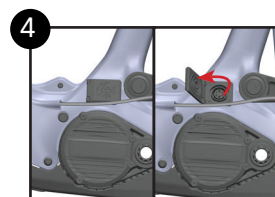



Avinox System Controls

- The system assist and functions can be controlled with (1) Control Display, (2) Left Wireless Controller and (3) Right Wireless Controller.
- **Become familiar with the operation of the controls before riding the e-bike.**

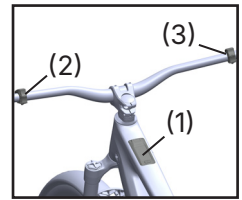

1. Control Display

- The power button is located in the bottom center of the Control Display. Press and hold the power button to turn the system on/off. If the e-bike has not moved for 10 minutes, the power will shut off automatically.
- Tap or swipe on the screen of the Control Display to view ride data screens and access settings.
- There is a USB-C charging port at the top of the Control Display that can be used to charge connected devices.
- The power button can also be used to change assist modes with a quick press.



2. Left Wireless Controller

- Press the assistance level increase button (upper button) to increase assist modes in order of Off> Auto> Eco> Trail> Turbo.
- Press and hold the up button to activate Boost mode and the e-bike screen will display a countdown. Press the power button or assistance level increase/decrease buttons to exit Boost mode.
- Press the assistance level decrease button (lower button) to decrease assist in order from Turbo> Trail> Eco> Auto> Off.
- Press and hold, the down button to activate Walk mode. Once activated, press and hold the button for walk assist functions. Press any other button to exit Walk mode.



3. Right Wireless Controller

- Customizable Screen Switch Button (upper button). Press to slide the e-bike screen display to the right.
- Customizable Function Button (lower button). Press to slide the e-bike screen display to the left.
- Swipe up on the e-bike screen to enter **Settings**, and then you can customize functions for the buttons in **Customize Controls**.



Smartphone Connection and App Pairing

- Scan the QR code to the right to download the Avinox App for your smartphone.
- When powering the e-bike on for the first time, follow the prompt on the e-bike screen to complete pairing and activation. Tap **Skip** and you can ride without activation for a trial period. After the trial distance runs out, follow the steps below to pair and activate.

1. Press and hold the power button. Swipe up on the screen to enter **Settings** and tap **Pair to App** to view the pairing QR Code on the screen.
2. Make sure Bluetooth and network are enabled on your mobile device.
3. Open Avinox App, then tap **Pair** and scan the QR code on the screen to pair.



Avinox
App



1. Always set sag with the climb switch lever to the open position. (fig. 1)
2. If your shock has additional compression and rebound adjustments ensure they are adjusted to be fully open, compression to the softest setting, and rebound to its fastest setting. Do this by rotating them fully counter-clockwise. (fig. 1)
3. FOX products have our sag indicator installed to quickly measure sag. RockShox products have sag percentage stamped on the shock shaft for easy reference. (fig. 2)
4. Find a level surface and something to steady yourself while mounted on the bike so you can be on the pedals in a seated position. It may be easier to have a partner hold your bike steady from the front, by holding the handlebars while you are in your riding position.
5. While standing on the pedals, sit down hard into the saddle to cycle the suspension well into the stroke. This will ensure the bike comes to rest at the natural sag setting with you in the saddle.
6. While in the saddle and not moving, slide the O-ring up into position against the air can. (fig. 3)
7. Once the O-ring is set in place, slowly step off the bike to not move the O-ring.
8. Make adjustments to the sag by removing or adding air so that steps 4-7 result in the O-ring lining up with the red line on the sag indicator on FOX Shocks. On RockShox the ideal sag is with the O-ring on the 30% line on the shock. (fig. 4) The preferred sag measurement for either shock is 16.5 mm.

When adjusting air pressure in the shock, cycle the shock at least 25% into its travel before re-checking sag, so the negative air chamber equalizes pressure with the main chamber each time air is added or removed. You can do this by pushing down on the saddle several times to compress the shock past the sag point.

***Do not exceed the maximum air pressure indicated on your shock.**

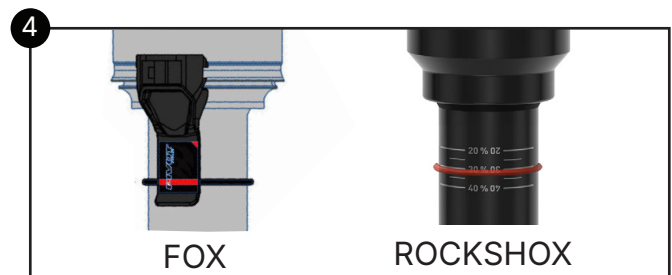
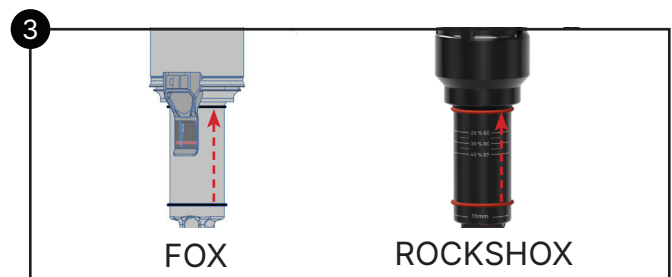
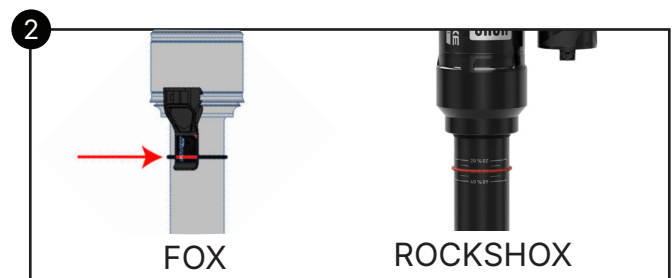
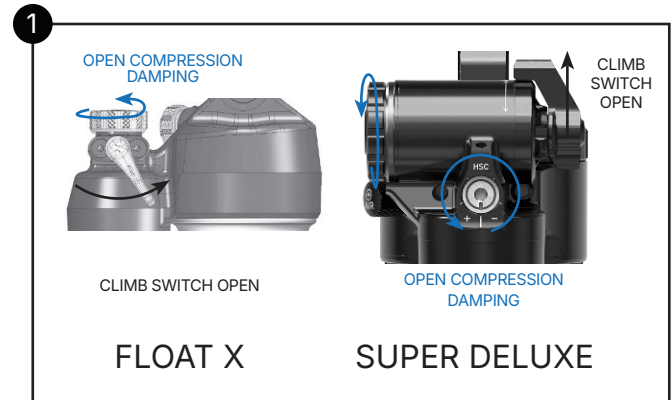



Rebound Damping

- Setting rebound is dependent on air pressure. For example, higher air pressures require a slower rebound setting.
- We set rebound from the most open or fastest position, so start by turning the rebound adjuster counter-clockwise all the way open.
- Refer to the table on the right for the suggested rebound setting based on the air pressure you have in your shock to achieve the correct sag. The bold numbers in the chart refer to how many clicks clockwise from the open setting. FOX suspension set up guides always count clicks from the closed position, which is listed in parentheses.

 Rotate counter-clockwise for faster return after compression

 Rotate clockwise for slower return after compression



Suggested Rebound Float X	
Shock Air Pressure	Clicks from OPEN (Clicks from CLOSED)
<120 psi <8.3 bar	3 (9)
120-140 psi 8.3-9.7 bar	3 (8)
140-160 psi 9.7-11 bar	5 (7)
160-180 psi 11-12.4 bar	6 (6)
180-200 psi 12.4-13.8 bar	7 (5)
200-220 psi 13.8-15.2 bar	8 (4)
220-240 psi 15.2-16.5 bar	9 (3)
240-260 psi 16.5-17.9 bar	10 (2)
260-280 psi 17.9-19.3 bar	11 (1)
280-300 psi 19.3-20.7 bar	CLOSED

Compression Damping

2-Position Lever

- Some Float X shocks feature a two position lever that allows for on-the-fly adjustment between fully open and firm for climbing. For most riding conditions it is best to have the lever open. As with other shocks, the firm setting is best suited for long fire road climbs and smooth XC courses.



Suggested Compression Float X	
Rider Weight	Clicks from OPEN (Clicks from CLOSED)
<120 [lbs] <54 [kg]	OPEN
140-150 [lbs] 63-68 [kg]	1 (9)
150-160 [lbs] 68-72 [kg]	2 (8)
160-170 [lbs] 72-77 [kg]	3 (7)
170-180 [lbs] 77-81 [kg]	4 (6)
180-190 [lbs] 81-86 [kg]	5 (5)
190-200 [lbs] 86-90 [kg]	6 (4)
200-210 [lbs] 90-95 [kg]	7 (3)
210-220 [lbs] 95-100 [kg]	8 (2)
220-230 [lbs] 100-104 [kg]	9 (1)
>230 [lbs] >104 [kg]	CLOSED

Low Speed Compression Adjuster

- The Factory Series Float X features a low speed compression adjuster, which can be used to fine tune the open mode of the compression damping. This adjuster offers 10 clicks adjust the open mode.
- Turning the adjuster clockwise will increase low speed compression damping. Turning the knob counter-clockwise will decrease low speed compression damping. You can experiment with all of these options to find the setting that provides the best compression support or plushiest feel for your weight and riding style. Refer to the table on the right for suggested starting settings.

Low Speed Compression Adjuster



 Rotate counter-clockwise to open compression (lighter)

 Rotate clockwise to close or increase compression (firmer)



Rebound Damping on the RockShox Super Deluxe

- Rebound is set from the most open (fully counter-clockwise) position.
- The rebound setting is determined by the air pressure in the shock.
- Refer to the table on the right for the suggested rebound setting. The bold numbers in the chart refers to how many clicks in (clockwise) from the open setting the rebound should be set. Clicks from the closed position, are provided in the table in parentheses.

Rebound Adjuster



*Rebound Knob shape and location may vary between shock models.

Suggested Rebound	
Air Pressure	Clicks from OPEN (Clicks from CLOSED)
<120 psi <8.3 bar	2-5 (9-12)
120-140 psi 8.3-9.7 bar	4-6 (8-10)
140-160 psi 9.7-11 bar	5-7 (7-9)
160-180 psi 11-12.4 bar	6-8 (6-8)
180-200 psi 12.4-13.8 bar	7-9 (5-7)
200-220 psi 13.8-15.2 bar	8-10 (4-6)
220-240 psi 15.2-16.5 bar	9-11 (3-4)
240-260 psi 16.5-17.9 bar	10-12 (2-4)
260-280 psi 17.9-19.3 bar	11-13 (1-3)
280-300 psi 19.3-20.7 bar	13-14 (1-2)

 Rotate counter-clockwise for faster return after compression

 Rotate clockwise for slower return after compression

Compression Damping on the RockShox Super Deluxe

Threshold Lever

- Some Super Deluxe shocks feature a two position lever that allows for on-the-fly adjustment between fully open and firm for climbing. For most riding conditions it is best to have the lever open. As with other shocks, the firm setting is best suited for long fire road climbs and smooth XC courses.

Threshold Lever



Low Speed Compression Adjuster

- Some Super Deluxe shocks feature a low speed compression adjustment knob, which can be used to fine tune the low-speed compression damping for low speed scenarios like rider weight shifts, cornering, or gradual bump impacts.
- This knob offers 5 clicks of adjustment. We recommend starting in the middle. Turning the knob clockwise will increase low speed compression damping, for a firmer feel. Turning the knob counter-clockwise will decrease low speed compression damping, for a softer feel.

Low Speed Compression Adjuster



High Speed Compression Adjuster

- Some Super Deluxe shocks feature a high speed compression adjustment knob, which can be used to fine tune the high-speed compression damping for high speed scenarios like square edge bumps.
- This knob offers 5 clicks of adjustment. Turning the knob clockwise will increase high speed compression damping. Turning the knob counter-clockwise will decrease high speed compression damping.
- We recommend starting with this one click counter-clockwise from the middle setting. If you are a very aggressive rider then rotating the knob clockwise, will provide more high speed compression damping.

High Speed Compression Adjuster

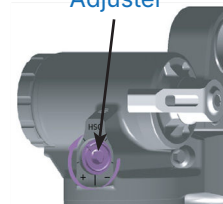

SETTING FORK SAG



- We recommend setting sag between 15% and 20% of the total fork travel. The Shuttle AMP'd comes with a 160 mm fork, so the proper sag measurement is 24.0 - 32.0 mm.
- To achieve proper sag, reference the chart to below for a starting point.
- Just like with the shock sag the fork needs to be equalized when the pressure is changed. Press down on the fork a few times after making a pressure change to get an accurate measurement.

***Do not exceed the maximum air pressure indicated on your fork.**

RIDER WEIGHT		FOX 38	ROCKSHOX ZEB
[kg]	[lbs]		
55 - 59	120 - 130	57 [psi] / 3.9 [bar]	98 [psi] / 6.8 [bar]
59 - 64	130 - 140	62 [psi] / 4.3 [bar]	108 [psi] / 7.4 [bar]
64 - 68	140 - 150	68 [psi] / 4.7 [bar]	118 [psi] / 8.1 [bar]
68 - 73	150 - 160	72 [psi] / 5.0 [bar]	128 [psi] / 8.8 [bar]
73 - 77	160 - 170	76 [psi] / 5.2 [bar]	138 [psi] / 9.5 [bar]
77 - 82	170 - 180	80 [psi] / 5.5 [bar]	146 [psi] / 10.0 [bar]
82 - 86	180 - 190	84 [psi] / 5.8 [bar]	154 [psi] / 10.6 [bar]
86 - 91	190 - 200	89 [psi] / 6.1 [bar]	161 [psi] / 11.1 [bar]
91 - 95	200 - 210	93 [psi] / 6.4 [bar]	170 [psi] / 11.7 [bar]
95 - 100	210 - 220	97 [psi] / 6.7 [bar]	174 [psi] / 11.9 [bar]
100 - 105	220 - 230	102 [psi] / 7.0 [bar]	179 [psi] / 12.3 [bar]
105 - 109	230 - 240	106 [psi] / 7.3 [bar]	184 [psi] / 12.7 [bar]
109 - 114	240 - 250	110 [psi] / 7.6 [bar]	190 [psi] / 13.1 [bar]

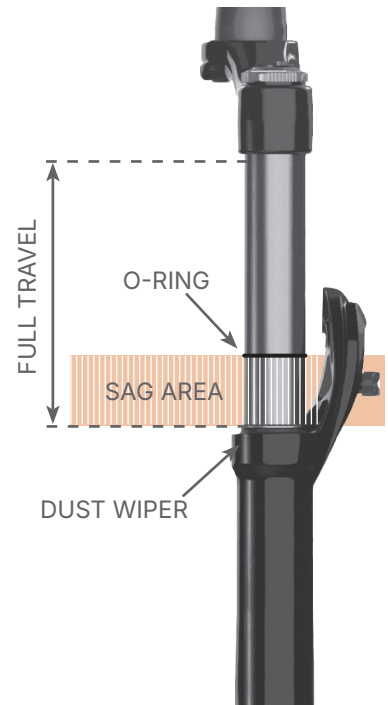

Setting Rebound Damping on the FOX 38 Forks

- Remove the protective cover over the rebound knobs on the lower fork leg.
- To set rebound, start from the open (or fastest) position by turning the red rebound dial(s) on the bottom of the right fork leg counterclockwise until it stops clicking. On the FOX 38 Grip X2 there are two dials. One for high speed and one for low speed.
- Refer to the chart below for recommended settings. Clicks from closed are in parentheses.

Suggested Settings Air Pressure [PSI]	GRIP X2 Rebound		Grip Rebound
	LSR	HSR	
<58 psi	3 (3)	0 (8)	1 (13)
58-62 psi	4 (12)	0 (8)	2 (12)
62-67 psi	5 (11)	1 (7)	3 (11)
67-72 psi	5 (11)	2 (6)	4 (10)
72-76 psi	6 (10)	2 (6)	5 (9)
76-80 psi	6 (10)	3 (5)	6 (8)
80-84 psi	7 (9)	3 (5)	7 (7)
84-89 psi	7 (9)	4 (4)	8 (6)
89-93 psi	8 (8)	5 (3)	9 (5)
93-97 psi	9 (7)	5 (3)	10 (4)
97-100 psi	10 (6)	6 (2)	11 (3)
100-104 psi	11 (5)	7 (1)	12 (2)
104-107 psi	12 (4)	8 (0)	13 (1)

Clicks from OPEN (Clicks from CLOSED)





Setting Compression Damping on the FOX 38 Grip X2 & Grip Forks

Grip X2 Forks

- To set compression, start from the open (or fastest) position by turning the black (LSC) knob and blue (HSC) knob counterclockwise until they stop clicking.
- Refer to the table on the right for suggested starting points based on rider weight.
- From the starting points, you may need to make adjustments based on riding style, preference, and terrain.



Suggested GRIP X2 Compression		
Rider Weight	LSC	HSC
	Clicks from OPEN (Clicks from CLOSED)	
<120 [lbs] <54 [kg]	3 (15)	1 (7)
120-150 [lbs] 54-68 [kg]	4 (14)	2 (6)
150-180 [lbs] 68-81 [kg]	5 (13)	3 (5)
180-210 [lbs] 81-95 [kg]	6 (12)	4 (4)
210-240 [lbs] 95-109 [kg]	7 (11)	5 (3)
>240 [lbs] >109 [kg]	8 (10)	6 (2)

Grip Forks

- We always start with the lever in the full open position. Most riders will not need to make any changes from this position.
- If you do need more compression support, the lever will provide a low speed compression adjustment until the lever is turned halfway. Fully closed provides a nearly locked out feel for climbing.

Setting Rebound Damping on the RockShox ZEB Forks

- To set rebound, start from the open (or fastest) position by turning the rebound dial on the bottom of the right fork leg counterclockwise until it stops clicking.
- Refer to the chart to the right for the recommended settings when setting rebound. Clicks from closed are in parentheses.

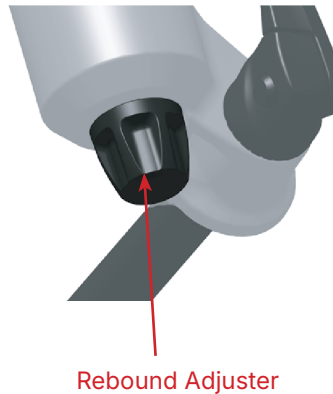

Suggested Air Pressure	ZEB
<98 psi	2 (13)
98-108 psi	2 (13)
108-118 psi	3 (12)
118-128 psi	4 (11)
128-138 psi	5 (10)
138-146 psi	6 (9)
146-154 psi	7 (8)
154-161 psi	8 (7)
161-170 psi	9 (6)
170-174 psi	10 (5)
174-179 psi	11 (4)
179-184 psi	12 (3)
184-190 psi	14 (1)
>190 psi	14 (1)

Clicks from OPEN (Clicks from CLOSED)

Setting Compression Damping on RockShox ZEB Forks

- ZEB forks feature two knobs on the top of the right fork leg. The upper knob is for low speed compression adjustment and the lower one is for high speed compression adjustments.
- We recommend starting with both of these set in the middle of the adjustment range. There are 5 clicks of adjustment for high speed and 15 clicks for low speed.
- Rotating the knobs counter-clockwise decreases compression damping, for a softer feel. Clockwise increases compression damping for a firmer feel.



Adjustable Bottom Out Control

- Some ZEB forks feature an adjustment to control the ending stroke with an independent mechanical bottom out feature. Adjustable Bottom Out (ABO) is easily tunable to rider preference without influencing the linear curve.
- Adjust the ABO by rotating the knob toward the + for more bottom out support, or toward the - for less bottom out support.

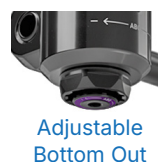



Riding Mode Customization

The standard modes of Auto, Eco, Trail, and Turbo provide a good range of assist levels for most riding situations. If you would like to adjust the parameters of any of these modes you can do this via the Avinox App. Turn your e-bike on and open the app and select Custom Assist Modes. With this menu you can change various settings to adjust for your riding preferences.

Walk Mode

Press and hold the down button on left wireless controller to activate Walk Mode. Once in Walk Mode, hold the button down for assistance when pushing the e-bike. This mode also support Auto Hold, to keep the e-bike from rolling backwards when on an incline. When the e-bike exceeds 6 kph (4 mph) or the button is released the assistance will end. Press any other button to exit Walk Mode.



Boost Mode

When enabled, this mode provides maximum assistance beyond what is provided by the standard assist modes for a limited time. Press and hold the upper button on the left wireless controller to activate Boost Mode. The display will show a countdown to inform you of the duration of the Boost Mode. When the countdown is complete or you press the power button or any button on the left wireless controller you will exit the mode.



***Use extreme caution with Boost Mode as it can be hard to manage on trails without being familiar with the power and assist behavior.**

SmoothShift

Shuttle AMP'd e-bikes that are equipped with an electronic SRAM Eagle Transmission connected to the Avinox drive unit with the AXS power cable (00.3018.418.001) can use the SmoothShift option. When enabled, the drive unit automatically detects gear changes to reduce power for smoother gear shifts. It also allows you to make gear changes while coasting. SmoothShift is enabled on the Control Display. Swipe up on the screen to find the SmoothShift menu item to enable or disable the feature. For safety, disable SmoothShift and set assistance to OFF during maintenance or when not actively riding.

System Updates

Like most modern devices, system improvements and features are developed over time. You can keep your e-bike current with the latest updates through the Avinox App. In the app you can install the updates to your e-bike. You can also take your e-bike in to your local Pivot Dealer for them to install any updates.

Troubleshooting

If the Avinox drive system detects an error a warning will appear on the control display screen. Swipe up on the screen and select Settings > System Status to see more information on the warning and steps to troubleshoot the issue. Visit an authorized dealer if the troubleshooting does not remedy the error.



Adding Accessories

You can use the control display to add compatible accessories to your e-bike.

- Swipe up on the display screen and select Accessories from the menu.
- Follow the prompts on the display screen for connecting your accessory to the system.

Integrating Lights

Avinox has a front light with high and low beam functions that can be operated with the wireless controllers. Pivot offers this light in a kit with a custom stem face plate and all required wiring in our webstore.

Third party lights can also be used with an Avinox accessory cable.

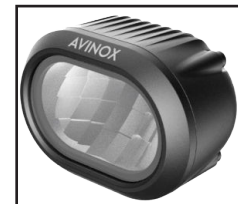

Pairing a Wireless Controller

If you need to pair a wireless controller the process is like adding accessories above.

- Swipe up on the display screen and select Accessories from the menu.
- Select the device you wish to replace and follow the prompts to forget the device.
- Install your controller on the bike and then hold down the upper and lower buttons at the same time for at least 5 seconds until the device LED flashes green rapidly.
- Tap add accessory on the display and select the device from the list to pair to the system.

Installing a nano-SIM Card

You can choose to install a nano-SIM card in your e-bike for further e-bike connectivity and Ride Data Sync. With a card installed the e-bike can be connected to the app via mobile data. Users can remotely control the e-bike, check e-bike status, and sync ride data to the cloud using the app.

- To install a nano-SIM card, use a 2 mm wrench to remove the display fixing bolts.
- Remove the Display from the top tube.
- Remove the fixing screws and cover from the SIM slot.
- Install the nano-Sim card.
- Replace the cover and torque the bolts to ≤ 0.1 Nm.
- Install the display fixing screws and torque to ≤ 0.6 Nm.
- After installing the nano-SIM card, power on the display, and open the Avinox app, tap Cloud and then enable Bike Connectivity (SIM).

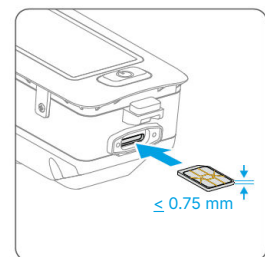
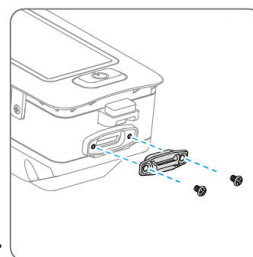
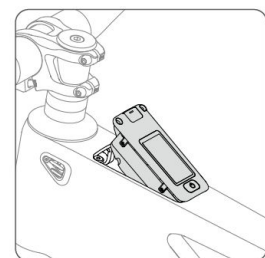
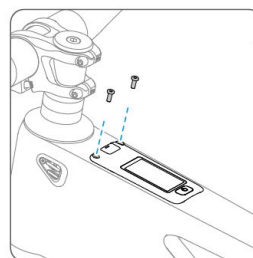

Bike Protection

The drive system provides e-bike protection functions, allowing users to set a digital password and use the phone as the Bluetooth key to unlock the e-bike automatically. These features can be enabled or disabled using the Avinox App.

Password Authentication- this can be enabled under Bike Protection > Password Authentication. Follow the instructions to set the password. After setting this up when you restart the e-bike enter the password to unlock the e-bike.

Mobile Key Unlock- if this feature is enabled, the e-bike will automatically lock when turned off. When you are close to the e-bike with your connected smartphone the e-bike will automatically unlock without entering the password.

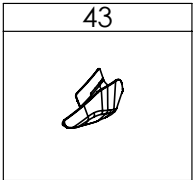
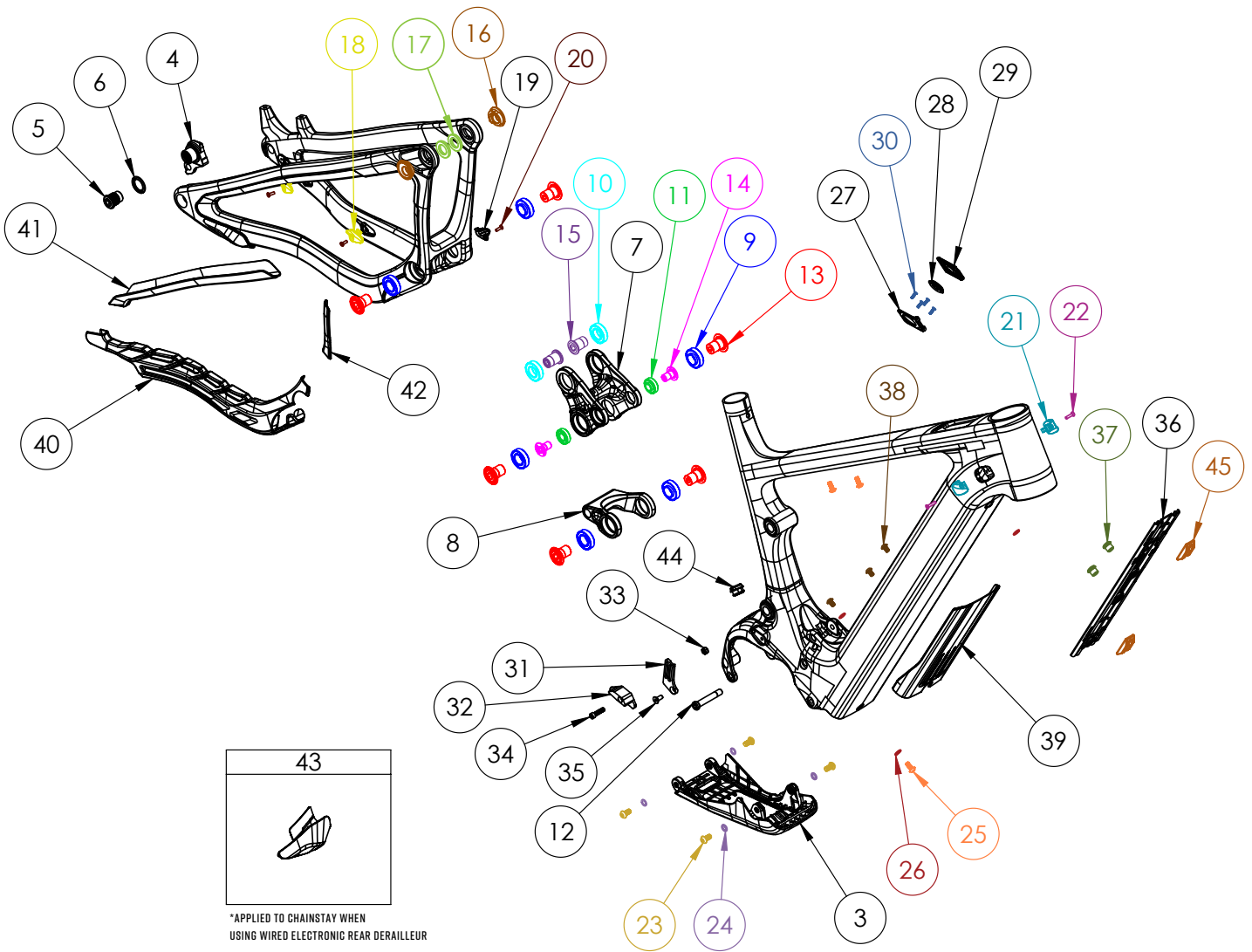

*APPLIED TO CHAINSTAY WHEN USING WIRED ELECTRONIC REAR DERAILLEUR

SMALL PARTS TABLE



HARDWARE				
NUMBER	PART NUMBER	DESCRIPTION	TORQUE	*
3	FP-CVR-SAMPI-SKD-VI-RI	SHUTTLE AMPD SKID PLATE		
4	FP-UDH-TA-I2MM-BLK-V2-RI	UNIVERSAL REAR DERAILLEUR HANGER		
5	[INCLUDED WITH #4]	UNIVERSAL REAR DERAILLEUR HANGER BOLT	25 NM (18 LB-FT)	
6	[INCLUDED WITH #4]	UNIVERSAL REAR DERAILLEUR HANGER WASHER		
7	FP-LNK-UL-66MM-VI-RI	66MM UPPER LINK		
8	FP-LNK-LL-50MM-V4-RI	50MM OUT-TO-IN LOWER LINK		
9	FP-BRG-6902-LLUMAXEGN	28MM 6902 EXTENDED MAX-E BEARING - BLACK OXIDE		R
10	FP-BRG-6902-LLUMAX	28MM 6902 STANDARD MAX BEARING - BLACK OXIDE		R
11	FP-BRG-6900-LLUMAXE	22MM 6900 EXT'D MAX-E BEARING - BLACK OXIDE		R
12	FP-BLT-M8*45.7-BLK-V2	M8 FRONT SHOCK BOLT FOR 30.1MM SHOCK SPACING	13 NM (10 LB-FT)	G / L
13	FP-BLT-MI4*20-BLK-V2-R2	MI4X20 LINK BOLT	35 NM (27 LB-FT)	L
14	FP-BLT-M10*16.5-BLK-VI	M10 TRUNNION MOUNT BOLT	13 NM (10 LB-FT)	L
15	FP-BLT-MI4*20-BLK-V3-R2	MI4X20 FLIP CHIP BOLT	35 NM (27 LB-FT)	L
16	FP-NUT-FLIPCHIP-4.6MM-VI	4.6MM FLIP CHIP		G
17	FP-WSH-SPC-I51*250*3W	MI4X3MM FLIP CHIP SPACER		G
18	FP-CLM-MECH-FRM-VI	INTERNAL ROUTING CABLE CLAMP		
19	FP-CLM-DUAL-FRM-VI	INTERNAL ROUTING DUAL CLAMP		
20	FP-SCW-FLT-M3*10-BLK	M3X10 CABLE PORT SCREW		
21	FP-CLM-PORT-SINGLE-VI-RI	DUAL PORT - SINGLE CLAMP		
22	FP-SCW-FLT-M3*15-BLK	DUAL PORT CLAMP SCREW BLACK		
23	FP-SCW-BTN-M6*12-VI-RI-BLK	M6X12 SKID PLATE MOUNTING SCREWS	6 NM (4.4 LB-FT)	L
24	FP-WSH-M6-BLK-VI-RI	M6 WASHER BLACK		
25	FP-BLT-BTN-M5*12-VI-RI-BLK	M5X12 BUTTON HEAD SCREW	5 NM (4 LB-FT)	L
26	FP-WSH-M5*10*1-VI-RI	M5 WASHER		
27	FP-MNT-BATT-CHG-V2-RI	AVINOX CHARGER MOUNTING PLATE		
28	FP-AVX-GKT-BATT-CHG-VI-RI	AVINOX CHARGER GASKET		
29	FP-AVX-CVR-BATT-CHG-VI-RI	AVINOX CHARGER TOP CAP		
30	FP-BLT-FLT-M2.5*10-VI-RI-BLK	M2.5X10 FLAT HEAD BOLT BLACK	1 NM (8.8 IN-LB)	
31	FP-MNT-CG-V5	CHAIN GUIDE MOUNTING PLATE		
32	CH I042B UPPER-20	UPPER CHAIN GUIDE		
33	[INCLUDED WITH #32]	M5 LOCKNUT		
34	[INCLUDED WITH #32]	M5X20 SOCKETHEAD SCREW		
35	FP-SCW-FLT-M5*12-BLK	M5X12 FLAT HEAD CG MOUNTING SCREW	5 NM (4 LB-FT)	L
36	FP-GDE-WIRE-PLATE-V2-RI	INTERNAL ROUTING PLATE		
37	FP-BLT-M10*8.5-VI-RI	INTERNAL ROUTING PLATE BOLT	2 NM (1.5 LB-FT)	G
38	FP-SCW-BTN-M5*8	M5X8 BUTTON HEAD SCREW		
39	FP-PRO-SAMPI-DT-VI-RI	SAMPI DOWNTUBE PROTECTOR		
40	FP-PRO-SAMPI-CS-VI-RI	SAMPI CHAINSTAY PROTECTOR		
41	FP-PRO-SLAMI-SS-VI-RI	SLAMVI SEATSTAY PROTECTOR		
42	FP-PRO-SLAMI-UR-VI-RI	SLAMVI UPRIGHT PROTECTOR		
43	FP-GDE-WIRE-VI-RI	SAMPI RD WIRE GUIDE		
44	FP-PLG-SPD-E-BIKE-VI-RI	SPEED SENSOR PLUG		
45	FP-PAD-INT-CABLE-ROUTE-VI	INTERNAL ROUTING PLATE PAD		

NOT PICTURED	PART NUMBER	DESCRIPTION	TORQUE	*
-	I57MM THROUGH AXLE V5	I57MM UDH REAR AXLE	15 NM (11 LB-FT)	G
-	-	I2MM AXLE WASHER (INCLUDED W/ AXLE)		G

BIKE CARE		
*	PRODUCT TYPE	RECOMMENDED PRODUCT
G	GREASE	MOTOREX BIKE GREASE 2000
L	THREAD LOCKER**	LOCTITE THREAD LOCKER #243 (OR EQUIVALENT)
G/L	GREASE (BOLT SHAFT) / THREAD LOCKER (BOLT THREADS)	SEE ABOVE
A	ANTI-SEIZE	MOTOREX COPPER PASTE
Y	LIGHT DUTY THREAD LOCKER	LOCTITE THREAD LOCKER #222 (OR EQUIVALENT)
R	RETAINING COMPOUND	LOCTITE RETAINING COMPOUND #638 (OR EQUIVALENT)

**THREADLOCKER SHOULD ALWAYS BE APPLIED TO THE CORRESPONDING FEMALE THREADS FOR THE BOLT SPECIFIED

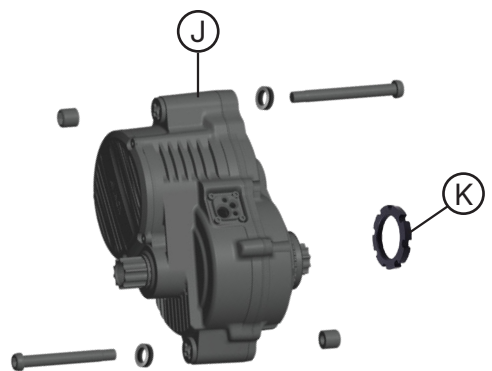
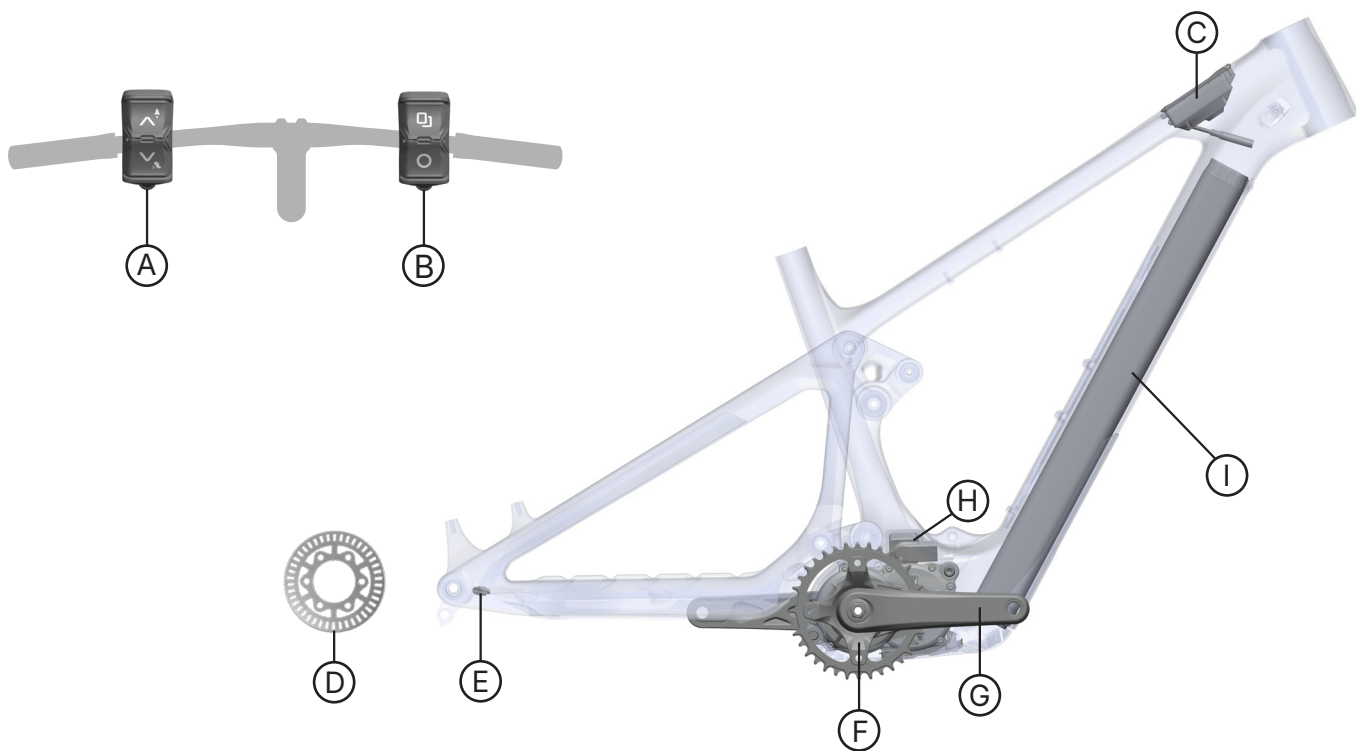

*DRIVE UNIT MOUNT WASHER KIT INCLUDES TWO SERRATED WASHERS. ALIGN THE LARGE SERRATIONS OF THE WASHERS ACCORDING WHITE DOT TO WHITE DOT, THEN PLACE THEM TOGETHER AND INSTALL THEM ONTO THE DRIVE UNIT MOUNT BOLT.

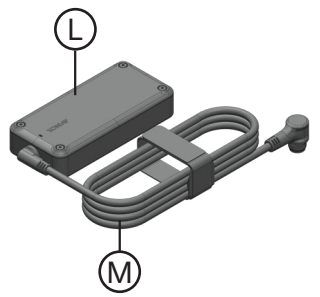

PARTS & COMPONENTS				
LETTER	PART DESCRIPTION	PART NAME	TORQUE	*
A	LEFT WIRELESS CONTROLLER	CP.EB.0000079.01		
B	RIGHT WIRELESS CONTROLLER	CP.EB.0000078.01		
C	CONTROL DISPLAY (NA REGIONS) CONTROL DISPLAY (GLOBAL REGIONS) DISPLAY CABLE (710MM)	CP.EB.0000104.01 CP.EB.0000105.01 CP.EB.0000096.01		
D	SPEED SENSOR RING	CP.EB.0000102.01		
E	SPEED SENSOR AND MOUNTING HARDWARE (650MM)	CP.EB.0000219.01		
F	SPIDER, BASH RING, AND CHAINRING	EP08A-DJAMI-DG-C55/ B650/ 00.6218.034.003		
G	CRANK ARMS (TEAM BUILD) CRANK ARMS (PRO & RIDE BUILDS)	EC-2ISIS-155AM EC-2ISIS-155CM		
H	CHARGING SOCKET	CP.EB.0000203.01		
I	800WH BATTERY AND MOUNTING HARDWARE	CP.EB.0000127.02	5 NM (4 LB-FT)	L
J	AVINOX M2S DRIVE UNIT AND MOUNTING HARDWARE	CP.EB.0000210.01	25 NM (18 LB-FT)	L
K	CHAINRING SPIDER LOCKRING	CP.EB.0000089.01	35 NM (27 LB-FT)	6
L	AVINOX 12A FAST CHARGER-NO POWER CABLE (TEAM AND PRO BUILDS) AVINOX 4A STANDARD CHARGER-NO POWER CABLE (RIDE BUILDS)	CP.EB.0000125.01 CP.EB.0000116.01		
M	12A CHARGER POWER CABLE (UK) 12A CHARGER POWER CABLE (AU) 12A CHARGER POWER CABLE (CN) 12A CHARGER POWER CABLE (US) 12A CHARGER POWER CABLE (EU)	CP.EB.0000120.01 CP.EB.0000121.01 CP.EB.0000122.01 CP.EB.0000123.01 CP.EB.0000124.01		
M	4A CHARGER POWER CABLE (UK) 4A CHARGER POWER CABLE (AU) 4A CHARGER POWER CABLE (CN) 4A CHARGER POWER CABLE (US) 4A CHARGER POWER CABLE (EU)	CP.EB.0000111.01 CP.EB.0000112.01 CP.EB.0000113.01 CP.EB.0000114.01 CP.EB.0000115.01		

NOT PICTURED	PART DESCRIPTION	PART NAME
-	DRIVE SYSTEM SCREW KIT	CP.EB.0000080.02
-	AVINOX LOCKRING TOOL	CP.EB.0000088.01
-	AVINOX MOTOR MOUNTING POINT ADJUSTMENT TOOL	CP.EB.0000211.01
-	DRIVE UNIT SCREW KIT (DRIVE UNIT FR MNT BOLTS, RR MNT BOLTS, 4 SPCRS, 2 MNT NUTS)	CP.EB.0000254.01



- The diagrams below will help illustrate how the wires are to be routed through the internal cable guides.
- The routing shown below will help minimize the likelihood of pinching a wire when performing maintenance on the drive system or components.

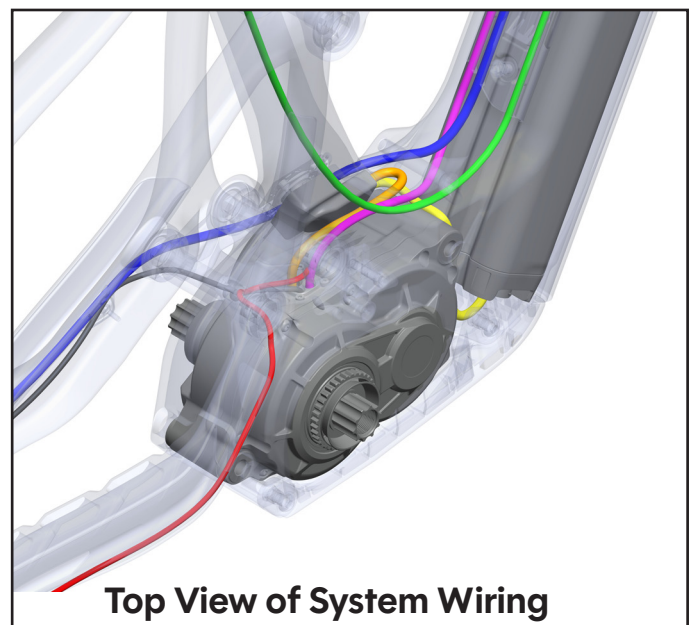
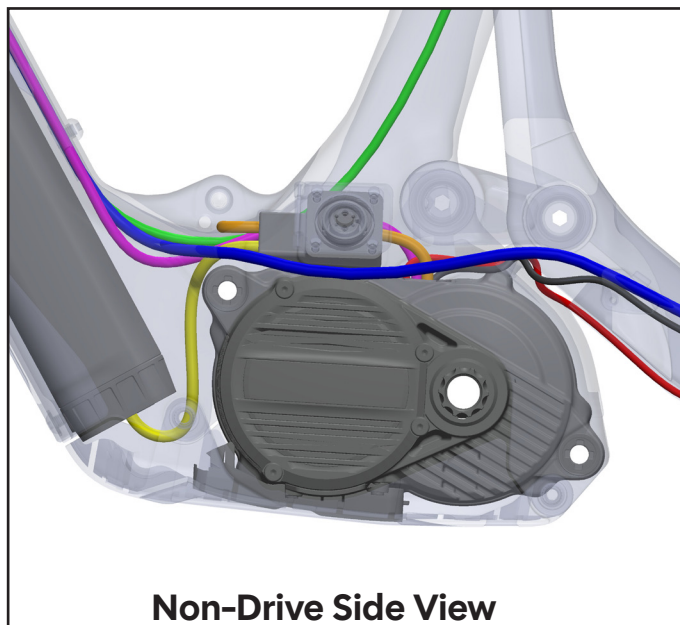
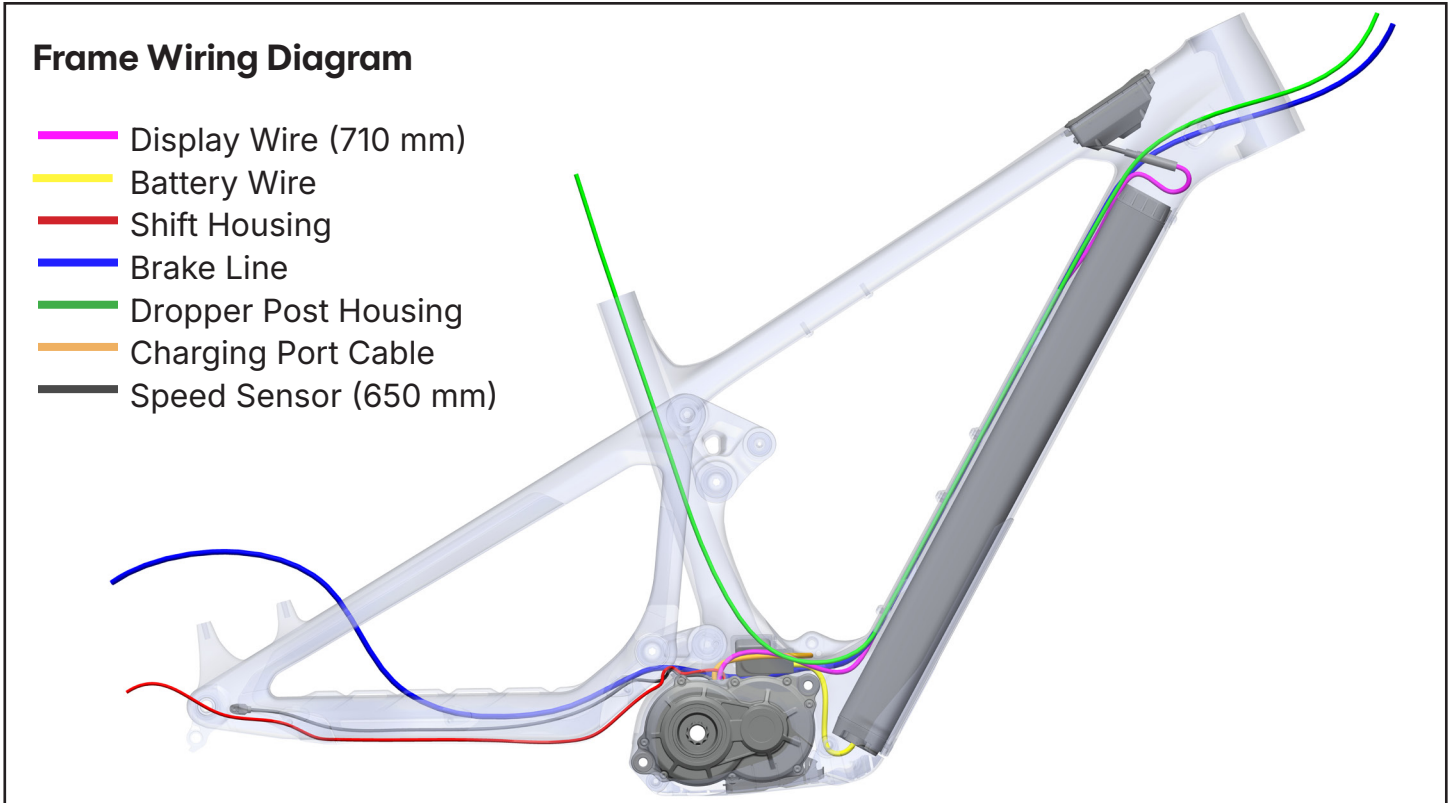



Bicycle Safety

According to the international standard ASTM F2043, the intended use of bikes is divided into five different categories, ranging from the use on paved roads through to downhill or freeride use. The Shuttle AMP'd is a category 4 all mountain bike.

This e-bike is not designed or equipped for use on public roads. Before it can be used on public roads it must be fitted with the legally prescribed equipment. It is designed to be used off-road, but not for competitions. The manufacturer and dealer accept no liability for damage resulting from any use beyond this definition and/or failure to comply with the safety information and instructions in this user guide. This applies particularly to, but not limited to, the use of this e-bike in competitions, overloading, and the failure to properly rectify faults. Intended use also includes conformance with the specified operating, service, and repair conditions in the user guides. Fluctuations in the consumption and power of the battery and a reduction of capacity with increasing age are common and technically unavoidable, and as such, do not constitute material defects. Changing the wheel sizes of this e-bike is a modification of the manufacturer's original specification and is not advised. Changes to wheel size may result in the e-bike not complying with e-bike classifications. Contact an authorized Pivot or Avinox dealer if you have questions regarding modification of the original specification.

Battery Safety

- Refer to the current Avinox battery manual from safety and care instructions before use.
- Batteries are subject to the dangerous goods regulations. Private users are permitted to transport them on the road without further conditions. If transported by commercial third parties (e.g. by air freight, logistics companies, or postal service) special conditions apply to packing and labeling. For questions about transporting batteries, please contact your local Pivot dealer.
- Damaged batteries must not be charged, used, or transported. They can explode and cause serious burns or fires. Gases can be released and irritate the airways. Ensure there is a supply of fresh air and consult a doctor in the event of discomfort. Liquid can escape and cause skin irritation. Avoid contact with this liquid, but in case of accidental contact, wash off with water. If the liquid gets into the eyes, flush out with water and seek medical attention.
- Batteries must not be submerged in water. There is a risk of explosion. Do not attempt to extinguish a burning battery with water, only the surrounding burning material. For burning batteries, use a Class D Fire Extinguisher. If it is possible to take the battery safely outside, smother the fire with sand. You do not need to worry that you are in danger when riding in the rain; the battery is protected from moisture and condensation.
- Clean the battery with a dry or, if at all, a slightly moist rag. Do not direct the water jet of a high pressure cleaner at the rechargeable battery or submerge the battery into water, as there is a risk of water entry and/or short-circuit.
- For more information on the proper handling of your rechargeable battery see the system instructions of your drive manufacturer.
- Charge your battery only with the supplied charger. Do not use the charger of any other manufacturer, not even when the connector of the charger matches your rechargeable battery. The rechargeable battery can heat up, catch fire or even explode!
- Keep the rechargeable battery and the charger out of the reach of children!
- We recommend that you charge your battery only during the day and only in dry rooms which have a smoke or a fire detector. Unplug the battery once it has been charged up.
- Keep the rechargeable battery and the charger away from moisture and water during the charging process to exclude electric shocks and short circuits.
- Do not use a rechargeable battery or a charger that is defective. If you are in doubt or if you have any questions, contact your Pivot dealer.



Battery Safety (Continued)

- Do not expose your battery or the charger to the blazing sun during charging.
- Do not charge any other electrical devices with the supplied charger of your Pivot e-bike.
- The drive is not approved for steam cleaning, high-pressure cleaning or cleaning with a water hose. The contact of the electronics or the drive with water can destroy the units. The individual drive components can be cleaned with a soft rag and neutral detergents. You may use a moist rag, but not excessive water. Keep the rechargeable battery dry and do not submerge it. Risk of explosion.
- Make sure your rechargeable battery does not show any damage, i.e. cracks, breakages or discolorations at the contact points. Do not use a battery with such damage. Bring a damaged battery to your Pivot dealer at once.
- Make sure your rechargeable battery is in sound condition. Do not open, disassemble or crush the battery. Risk of explosion!
- Make sure your rechargeable battery is not exposed to mechanical impacts.
- Keep your battery away from fire and heat. Risk of explosion!
- Batteries must not be short-circuited. Therefore store them in a safe storage area and make sure the battery is not short-circuited accidentally (e.g. with metal or another battery). In addition, rechargeable batteries must not be stored inappropriately, e.g. in a box or in a drawer where they can be short-circuited by other conductive materials or where they can short-circuit each other. Do not deposit any objects in the storage area (e.g. clothes).
- Make sure to use the battery only for the Pivot e-bike for which it is designed.
- Remove the rechargeable battery if you do not use your Pivot e-bike for a long period of time (e.g. during the winter season). Store the rechargeable battery in a dry room at temperatures between 5 - 20°C (41 - 68°F). The state of charge should be 50 - 70% of the charging capacity. Check the state of charge if the rechargeable battery is left unused for more than two months and recharge it in between, if necessary, to 50%.
- The battery does not come charged and must be charged completely before the first use.
- When removing the charger from the outlet or the port, pull on the plug, not the cord.
- When charging the battery, plug the cord into the wall outlet first, and then into the battery.
- Be sure that the charger is on a flat and stable surface, when charging.
- Do not leave the battery fully depleted for an extended period of time. This will cause the battery to deteriorate and reduce the battery capacity.
- Keep the rechargeable battery and the charger away from moisture and water during the charging process to avoid electric shocks and short circuits.
- Keep the charger and battery out of reach of children.
- Do not use a battery or a charger that is defective. If you are in doubt, contact your Pivot dealer.
- If the rechargeable battery or the charger (or parts of it) must be replaced, only use original spare parts. Contact your Pivot dealer.
- Charge the battery at an ambient temperature of approximately 20°C (68°F). Therefore, before starting the charging, wait until the temperature of the battery has increased or decreased after a ride in cold or hot weather.
- Do not dispose of your rechargeable battery in the normal household rubbish! It must be disposed of according to battery disposal regulations. Therefore, sellers of new rechargeable batteries must provide collection of old batteries and appropriate disposal. If you are in doubt or if you have any questions, contact your Pivot dealer.
- When the battery is fully charged, remove the charger.
- Observe the notes on the respective labels on the rechargeable battery or on the charger.



Avinox Drive System

Additional information regarding safety, operation, functionality of the Avinox Drive System, its components, software and mobile apps can be found on their website by scanning the QR code to the right.



Avinox

Pivot Shuttle AMP'd

For FAQs and additional technical documents regarding the maintenance of the Pivot Shuttle AMP'd can be found on by scanning the QR code to the right.



Pivot

Battery Recycling Information

Pivot is a proud partner of the The Battery Network recycling program. When you are ready to replace your battery, your local US Pivot dealer can take care of properly shipping your battery to be recycled.

MY SUSPENSION SETTINGS

Shock Air Pressure

Shock Rebound Clicks LSR HSR

Shock Compression Clicks LSC..... HSC

Fork Air Pressure

Fork Rebound Clicks LSR..... HSR

Fork Compression Clicks LSC..... HSC

NOTES

.....
.....
.....
.....



6720 South Clementine Court
Tempe, AZ 85283

T +1 480 467 2920
info@pivotcycles.com
www.pivotcycles.com