

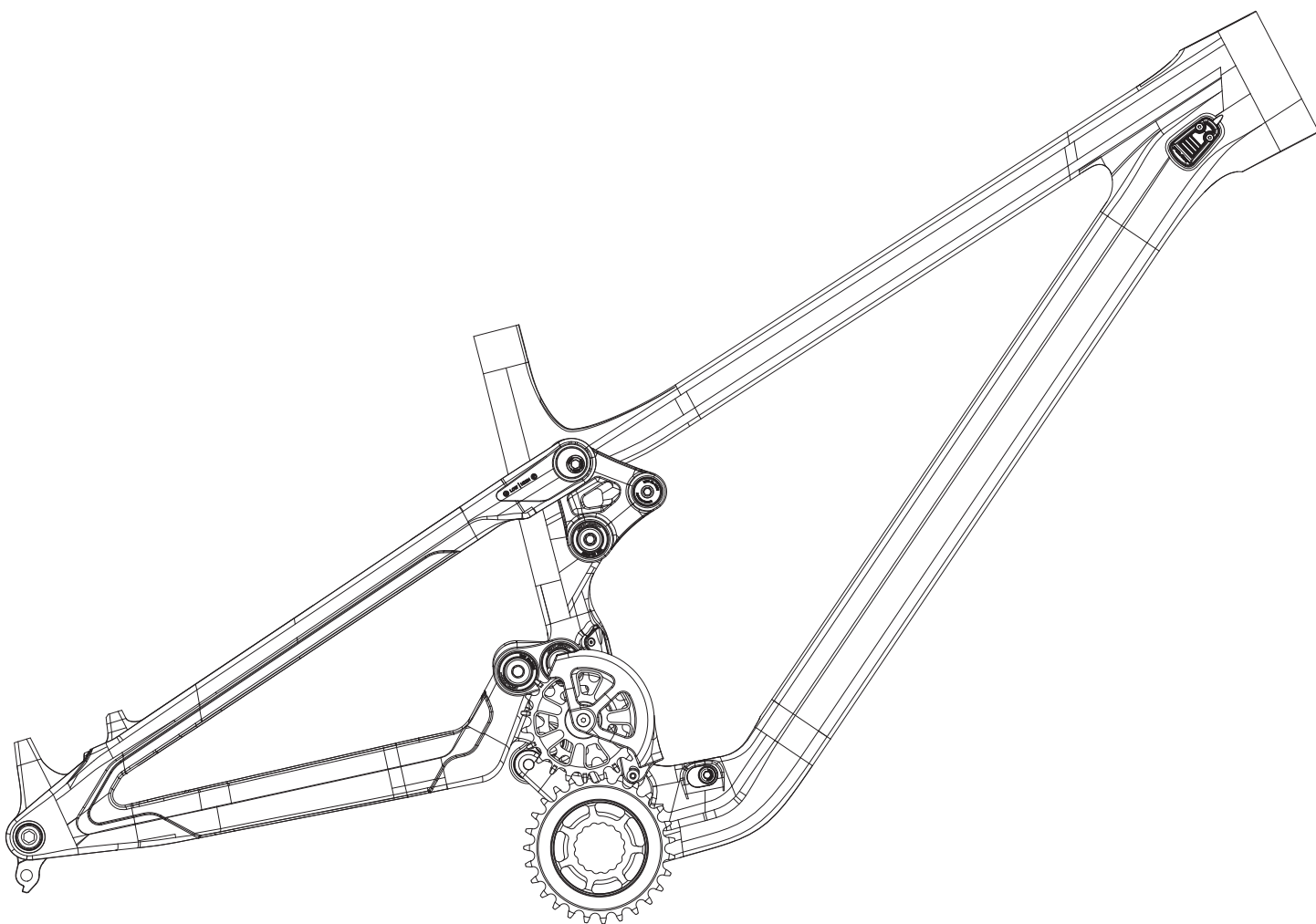

The latest generation of the Phoenix has several frame features you need to know about for maintenance or for personal setup preferences. This document will help you with the adjustments and setup of these frame features.

| TABLE OF CONTENTS | PAGE |
|---|----------|
| 1. Bottom Bracket & Crank Installation | 1 |
| 2. Mid-Drive Dual Chain Setup | 3 |
| 3. Geometry Adjust Flip Chip | 7 |
| 4. Progression Adjust Flip Chip | 8 |





The Phoenix uses a custom bottom bracket, chainrings, and crankset made for Pivot by Praxis. The bottom bracket bearings are side specific. Refer to the small parts schematic for part numbers.

1.) The drive side bottom bracket bearings is 30mm and the non-drive side is 28mm.

2.) Apply purple Loctite 222 or equivalent to the bottom bracket shell and spread evenly around.



3.) Press the bearings into the frame confirming the 30mm on DS and 28mm on NDS.

4.) Apply Motorex Bike Grease 2000 or an equivalent waterproof grease to the inner races.





5.) The crank spacers are side specific and must be installed as shown.

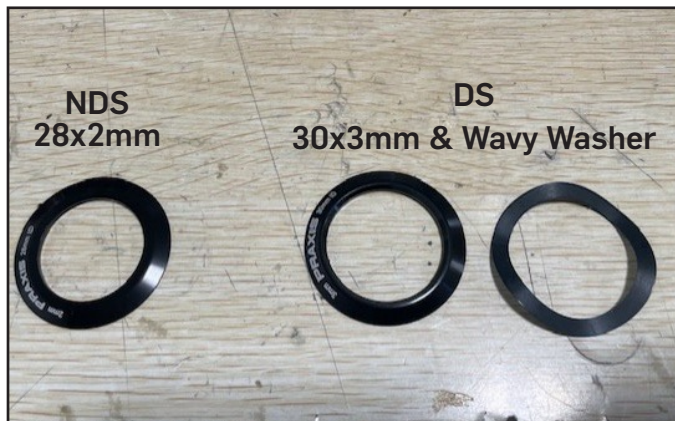

6.) Slide the wavy washer onto the crank spindle.



7.) Next slide the 30x3mm washer onto the crank spindle.



8.) Install the crank into the bottom bracket.



9.) Install the 28x2mm spacer on the non-drive side of the bottom bracket.



10.) Apply Motorex Bike Grease 2000 or an equivalent waterproof grease to the spindle and install the NDS crank arm and torque to spec.



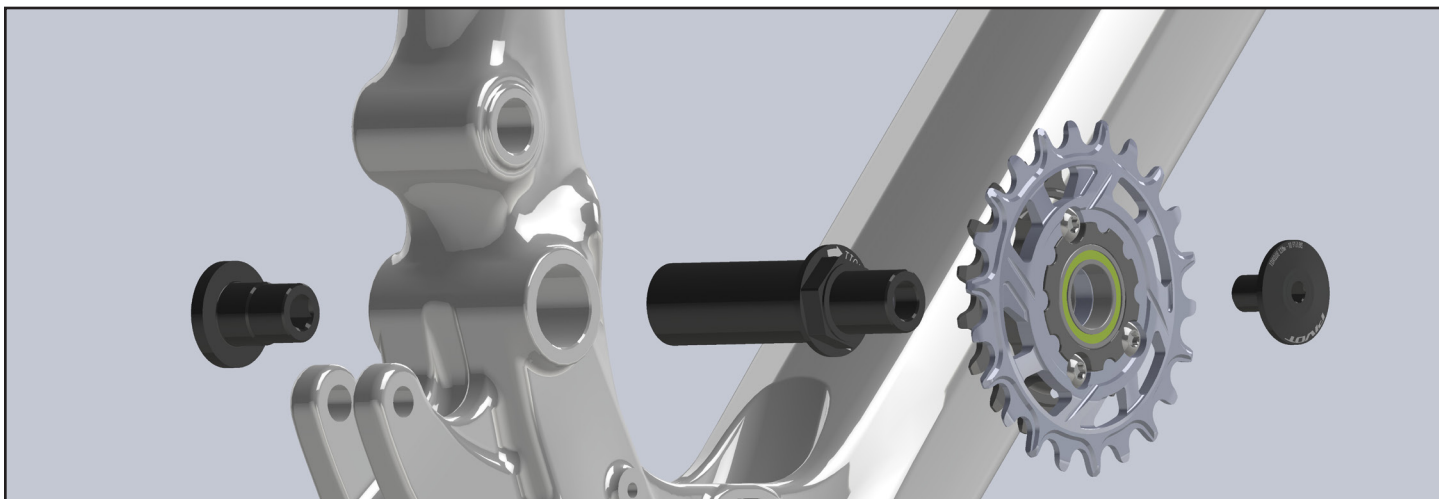

Once you have installed the bottom bracket and cranks you will install and adjust the mid-drive gears.

1.) If not already installed, gather the mid-drive frame parts.

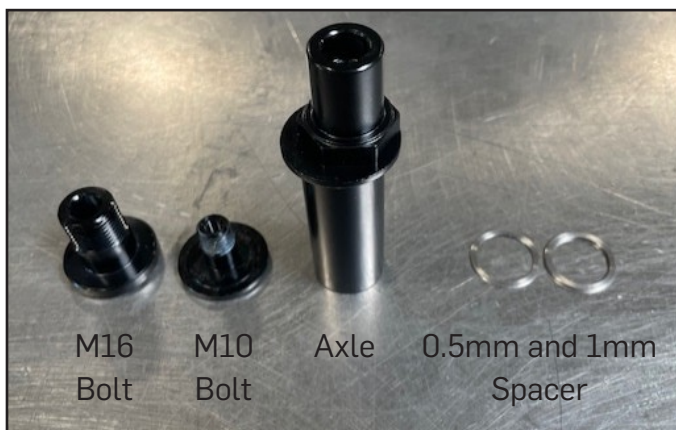

2.) Apply Motorex Bike Grease 2000 or an equivalent waterproof grease to the axle.



3.) Install the axle in the drive side of the frame with the eccentric spindle positioned at the bottom.



4.) Apply Motorex Bike Grease 2000 or an equivalent to the M16 bolt threads and body.





5.) Install and snug the M16 Bolt into the non-drive side of the mid-drive axle.



6.) Install the mid-drive gears on the axle.



7.) Check that the chainring is aligned with the inner mid-drive gear.

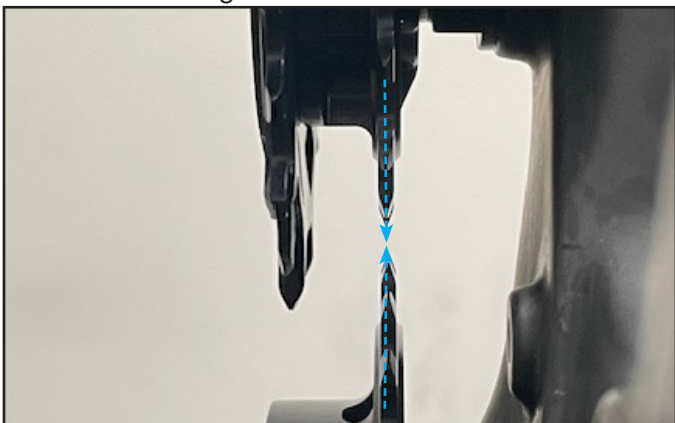

8.) The 0.5mm and 1mm spacers can be used to adjust for the best chainline.



9.) Once you have your spacer configuration for the best gear alignment, remove the parts and apply grease to the spindle.

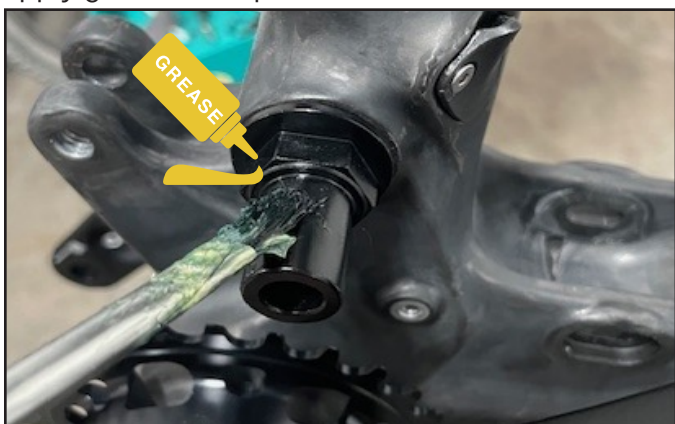

10.) If needed reinstall spacers for proper alignment.





11.) Install the gears on the axle and thread in the M10 bolt.



12.) Torque the M10 bolt to 13Nm.



13.) Assemble the eleven speed 38-link inner chain.



14.) Install the chain on the 17t inner gear and the chainring. Rotate the cranks to seat the chain.



15.) For proper chain tensioning start with the eccentric axle at the bottom and rotate it clockwise. Proper tension should be between 180° and 360°.

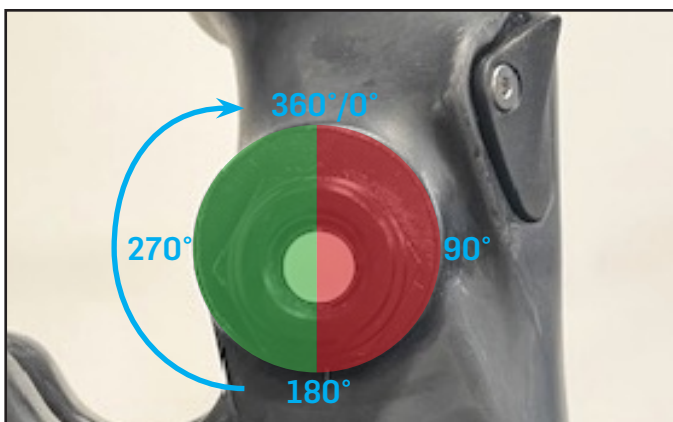

16.) Use a 22mm wrench on the flats of the mid-drive axle. Rotate clockwise to tension the chain.



MID-DRIVE DUAL CHAIN SETUP



Note: There are sometimes high or tight spots between the chainrings that can be felt when turning the cranks. To fix this, find the where the chain is tightest and reset the chain tension keeping the cranks in this position.

17.) Once the chain is running smooth through the full rotation, hold the wrench in place.



18.) Keep your adjustment setting with the wrench and torque the axle bolt to 35Nm.



19.) Rotate the cranks and confirm that the inner chain can't be derailed. (Outer drive ring removed for better chain visibility.)

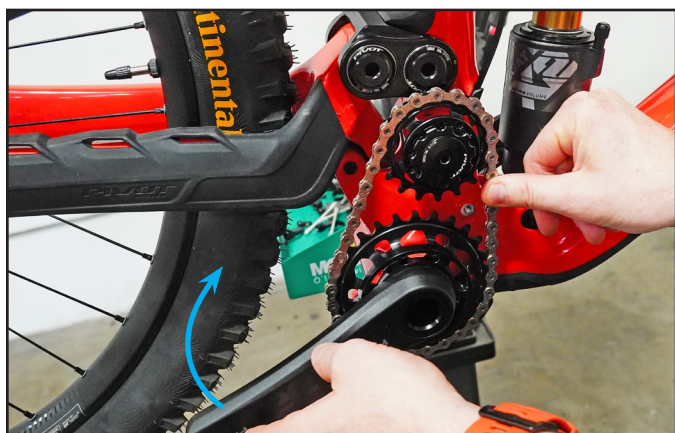

20.) Install the outer chain from the derailleur over the outer 22t chainring.



21.) Align the chain guard over the rings.

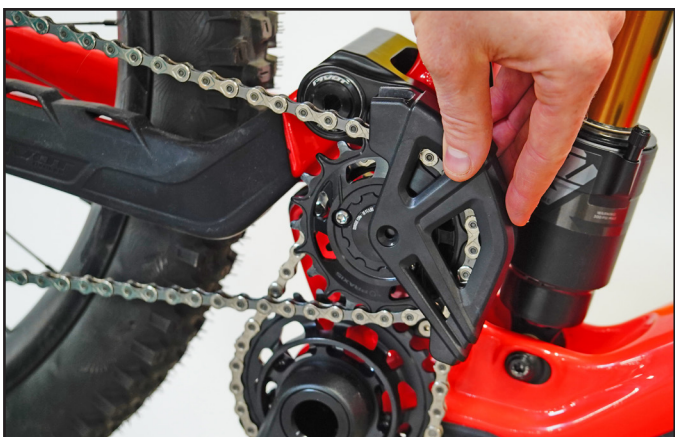

22.) Install the two chain guard screws and torque them to 3Nm.



GEOMETRY ADJUST FLIP CHIP



The geometry flip chip on the Phoenix has two positions. The LOW position is perfect for riding fast, technical and steep terrain. For a little more crank clearance and slightly quicker handling for tighter terrain with more roots and rocks, you may prefer the HIGH setting. The HIGH setting will raise the bottom bracket and steepen the head angle by 1/2 degree giving the bike faster turn in.

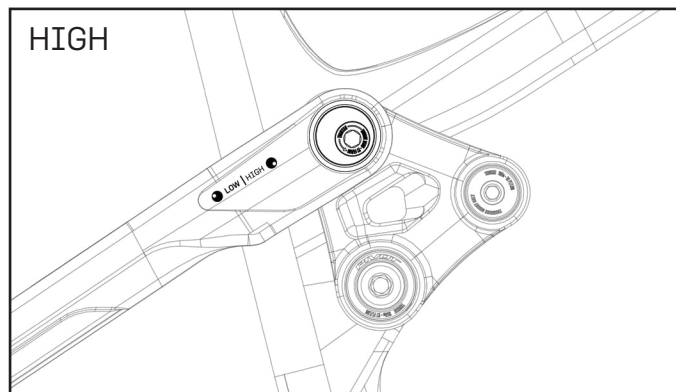
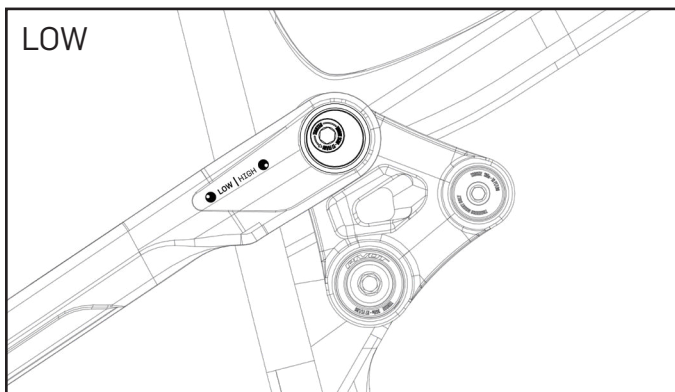

1.) Begin by loosening the flip chip bolts using a 6mm hex wrench. The bolts are inserted from the inside of the link so to loosen them from the outside you will need to rotate the wrench clockwise.



2.) Partially back out the bolts 3-4 rotations—there is no need to completely remove the chips. Once both sides are loose, you can rotate them to your desired setting.



3.) Press the chips back into the frame and snug both bolts down turning the wrench counter-clockwise to tighten.



4.) Torque both chips down to 35Nm by setting your torque wrench counter-clockwise. Refer to the Small Parts Schematic for assembly compounds.





The Phoenix comes with the progressivity flip chip in the linear setting. This being with the lower shock bolt in the forward position. This is perfect for most riders and most tracks. The more progressive setting is with the chip flipped so the shock bolt is to the rear position. This more progressive setting is based on Bernard Kerr's personal preference.

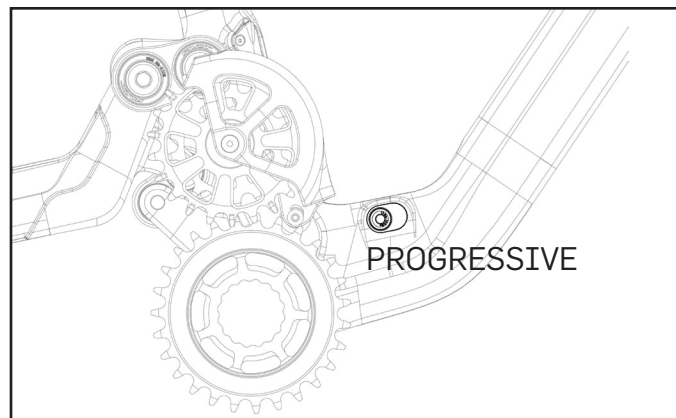
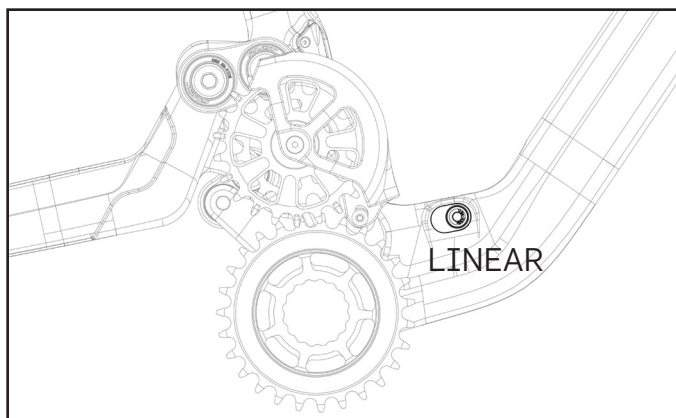

1.) To change the progressivity flip chip positions, begin by loosening the lower shock bolt.



2.) Loosen the shock bolt until the non-drive side flip chip can be removed from the frame.



3.) Pull the drive side flip chip out of the frame pocket and rotate it 180°. Move the shock back or forward and reinsert the flip chip.



4.) Align the non-drive side flip chip and tighten down the shock bolt. Torque the bolt to 13Nm. Refer to the Small Parts Schematic for assembly compounds.

